

TRANSIT

Rethinking bus stops for community impact

GUIDE

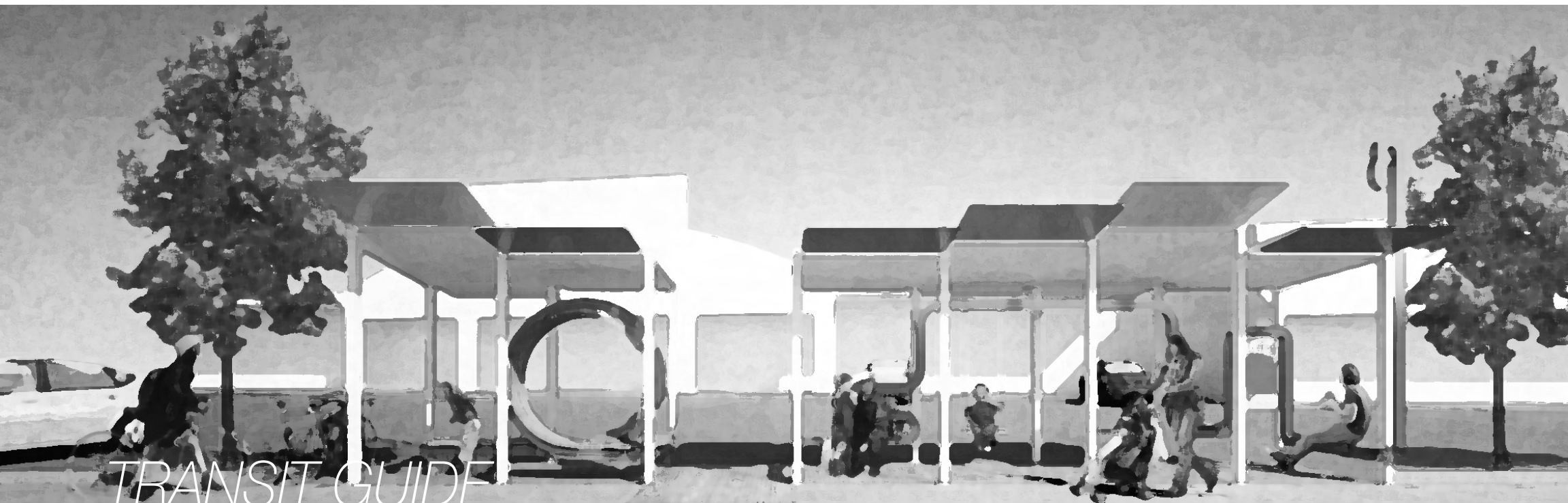



TRANSIT GUIDE

Rethinking bus stops for community impact

Center for Public Interest Design

*Sergio Palleroni, Director
Todd Ferry, Associate Director
B.D. Wortham-Galvin, CPID Faculty*

Center for Public Interest Design Project Staff

*Rosemary Hill
Lisa Patterson
Marta Petteni
Matthew Rusnac*

Sacramento Area Council of Governments

*Kacey Lizon, SACOG Planner Manager
Monica Hernandez, Communications Manager
Greg Chew, Senior Planner*

Research and Visualization

*Portland State University Architecture
Students in conjunction with CPID*

Why focus
on
transit
for
community
impact



INTRODUCTION



INTRODUCTION

Welcome to the Transit Guide for Community Impact created by the Center for Public Interest Design (CPID) in collaboration with the Sacramento Area Council of Governments (SACOG). This guide is intended to be a useful resource for both transit agencies and communities that will hopefully be a meaningful tool toward the production of an enhanced community bus stop, and facilitate conversation between these groups and other stakeholders involved in its sponsorship and programming.

This guide is one of the outcomes of a multi-year partnership between SACOG and the CPID exploring design and place-making opportunities that can address the needs of underserved communities in the Sacramento area. The larger collaboration supports design interventions at multiple scales in order to improve the social, economic, and environmental conditions of the city's neighborhoods. The CPID began this effort by establishing connections with Mutual Assistance Network (MAN) of Del Paso Heights and La Familia Counseling Center in South Sacramento, which became the focus of research and design investigations. Following a series of design visioning periods informed by community engagement activities conducted by the CPID and partners, improved transit, and the access it would provide these communities, emerged as an important goal anchoring all other community improvement and development goals of both areas. This guide is a product of this visioning and these exchanges, with a focus on the possibilities provided by rethinking transit design and investment as an opportunity to address broader community needs. Out of the dozens of design proposals aimed at maximizing community impact, the concept of pursuing improvements to neighborhood transit and leveraging that investment to provide much-needed community amenities proved to be an idea strongly embraced by the widest range of stakeholders.

While there are institutional and practical challenges associated with it, this approach to reconsidering the bus stop within the framework of maximizing community impact:

- *Offers new possibilities to support transportation, design, and growth in communities through mechanisms such as Cap and Trade.
- *Has the potential to improve rider experience and increase choice ridership.
- *Can help build community buy-in to transit development and support its role in its community.
- *Can serve as an important catalyst for change and inform future investment, assets, and support in disadvantaged areas by both the public and private sector.
- *Enables a participatory process that in itself can empower communities and make each bus stop belong to its community
- *Supports the idea that each bus stop can be a gateway and amenity to its community and, as such, a symbol of its values and unique character.

This guide is organized to provide the necessary steps to begin and advance the design of a community-based enhanced bus stop through a look at design considerations leading to its implementation, including the strategic opportunities for participatory involvement by the subject communities and stakeholders. This guide will also present place-making precedents, introduce strategies for meaningful community engagement, provide case studies of proposed and existing bus stop designs, and suggest opportunities for small-scale interventions when a new bus stop isn't possible. While the visions suggested in this guide were developed to support development plans in each subject community, the CPID looks forward to testing these ideas with a partner agency in Sacramento through a prototype bus stop made possible with support of the Sacramento Air District. The design and construction process will follow the transit guide outline, allowing for informed revisions and a proof of concept for a new approach to transit design.

CPID

The Center for Public Interest Design (CPID) is a research [+action] center at Portland State University that aims to investigate, promote, and engage in inclusive design practices that address the growing needs of underserved communities worldwide. Through research and design, fieldwork, and public outreach, we promote a mode of practice that is socially conscious, environmentally sustainable, and economically accessible to all.



TABLE OF CONTENTS

INTRODUCTION

[Why focus on transit for community impact?]

CHAPTER 1: THEORETICAL BACKGROUND

[How is an enhanced bus stop more than a bus stop?]

- Intro
- Participatory design approach: the power of engaging communities
- "___" As a Bus Stop
- Process Diagram

CHAPTER 2: BUS STOP POLICIES AND REGULATIONS

[What are basic considerations when beginning bus stop design?]

- Intro
- 2.1 Elements of a Bus Stop
- 2.2 Bus Stop Parameters

CHAPTER 3: PLACEMAKING

[How do you insert placemaking into bus stop design?]

- Intro
- 3.1 Precedents
- 3.2 Proposals for Sacramento

CHAPTER 4: COMMUNITY ENGAGEMENT

[How can the community be empowered by the design process?]

- Intro
- 4.1 Design Charrette
- 4.2 Community Created Infographics
- 4.3 Directed Feedback Activities
- 4.4 Unstructured Activities
- 4.5 Online engagement

CHAPTER 5: ENVISIONING (NEW) BUS STOPS

[What might an enhanced bus stop look like?]

- Intro
- 5.1 Students proposals
- 5.2 Built precedents
- 5.3 Sacramento Philharmonic Stop

CHAPTER 6: IMPLEMENTING (EXISTING) BUS STOPS

[How do we make impact when time, resources and money are limited?]

- Intro
- 6.1 Bus Stop Interventions

APPENDICES

- A-Context analysis of Sacramento
- B-"With Sacramento" interactive tool

*How is
an*

enhanced

bus stop

*more than
a bus stop*

CHAPTER I: THEORETICAL BACKGROUND

The contemporary urban experience relies on complex systems of transportation. Many major cities function through a combination of buses and trains that establish more sustainable means of transportation. A series of transportation stops or “nodes” collectively link to create larger, transit-based urban networks. Designing these transit stops through a process of community engagement establishes a sense of place and identity for a street, a neighborhood or a city. In other words, the transit stops form community “gates” that in turn establish a series of impactful design solutions across the city.

The research on public transportation as a tool for community growth and engagement considers cultural, environmental, and economic perspectives. Nabeel Hamdi investigates how incremental changes at the community scale result in a larger-scale urban impact. “He uses examples from cities in the global South, writing of how the smallest change, such as the installation of a bus-stop that results in a group of people waiting, induces a whole host of small-scale economies...”¹ and community opportunities. In *Small Change*, Hamdi analyzes this potential by stating: “Build a bus stop ... and a vibrant community sprouts and grows around it.” His theories support the idea that community engaged, co-design of public spaces create a more cultural, environmental, and economically sustainable place. The problematic effects of gentrification manifest themselves in changes to a community that do not acknowledge the people living there. Each community makes up a neighborhood that collectively creates a city.

By addressing changes and developments through a community-engaged process, the unique attributes that individuals bring to the table reflect in the design and identity of the community’s spaces.

1. Hamdi, Nabeel. *Small Change : About the Art of Practice and the Limits of Planning in Cities*. London: Earthscan, 2004.

If a bus stop represents the design decisions of a community, then investment develops for the longevity of the space. An example of this would be designing a bus stop for a farmer's market. The stop becomes an important destination that brings together organizations from the community to gather and support healthier, more sustainable livelihoods and local economies. Each bus stop becomes a hub for potential cultural activity. Investment in these spaces "...allows a criss-crossing of an array of different cultural configurations."² In his thesis work, Kurvin Virahsawmy supports the theory that transportation becomes a positive way to create soulful public space. By investing in public transportation, the city establishes meaningful design projects that not only address the individual social, economic, and environmental needs of a place but also connect the communities to a larger urban existence.

2. Virahsawmy, Kurvin. *An Oasis for the Urban Nomad: Public Transport as an Advocate for Publicness*. Digitally Published, 2013.

“ AS A BUS STOP ”

Organization with a need + Transit Agency with a need

START WITH: An existing bus stop
A new bus stop
A potential bus stop

The following diagram proposes a general approach to the design of transit stops that incorporates engagement with a community. Rather than imagining a bus stop as “_____”, it envisions existing elements of a community as potential design opportunities. What if these aspects of the community became our bus stops?

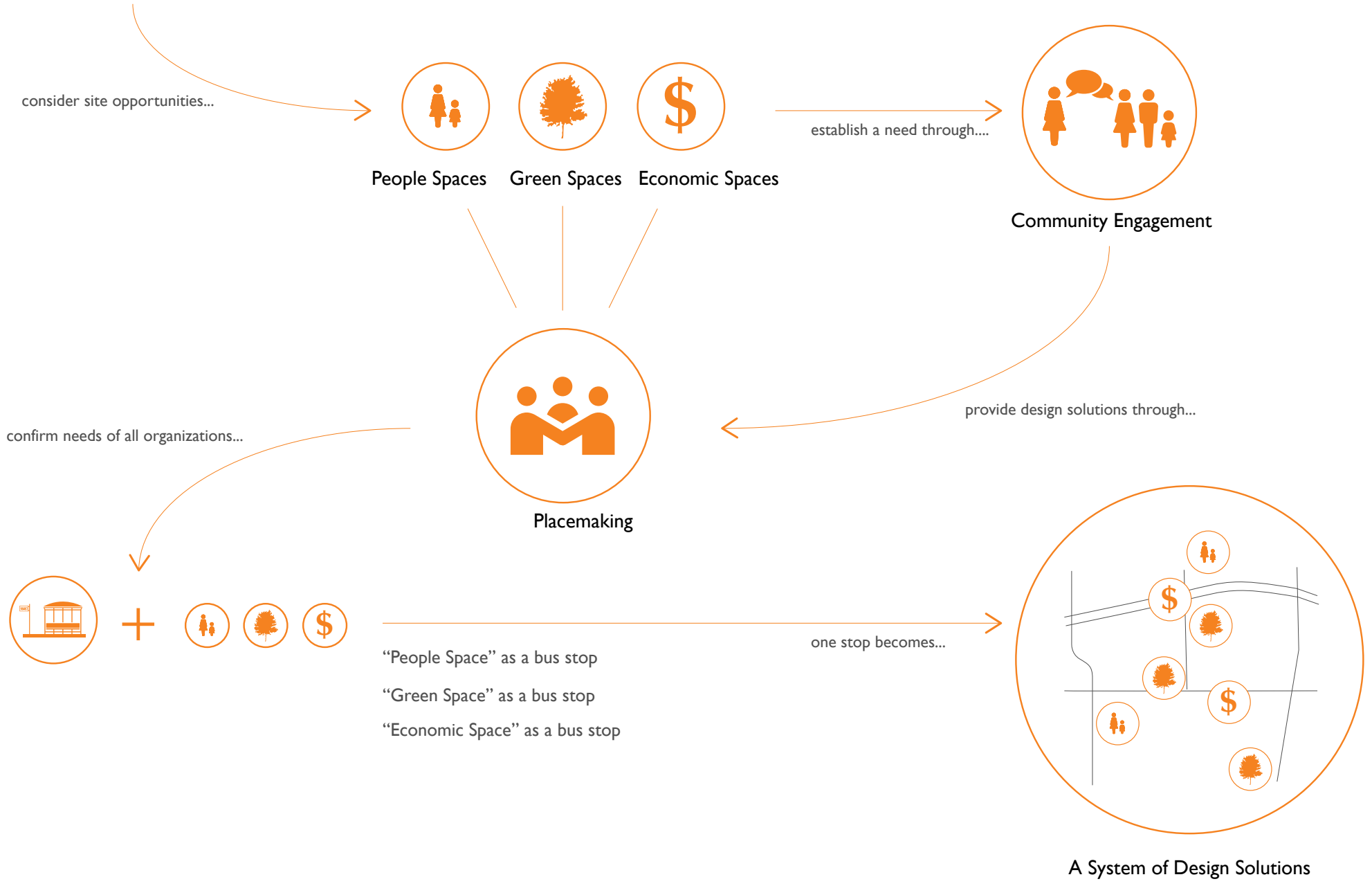

TIMELINE

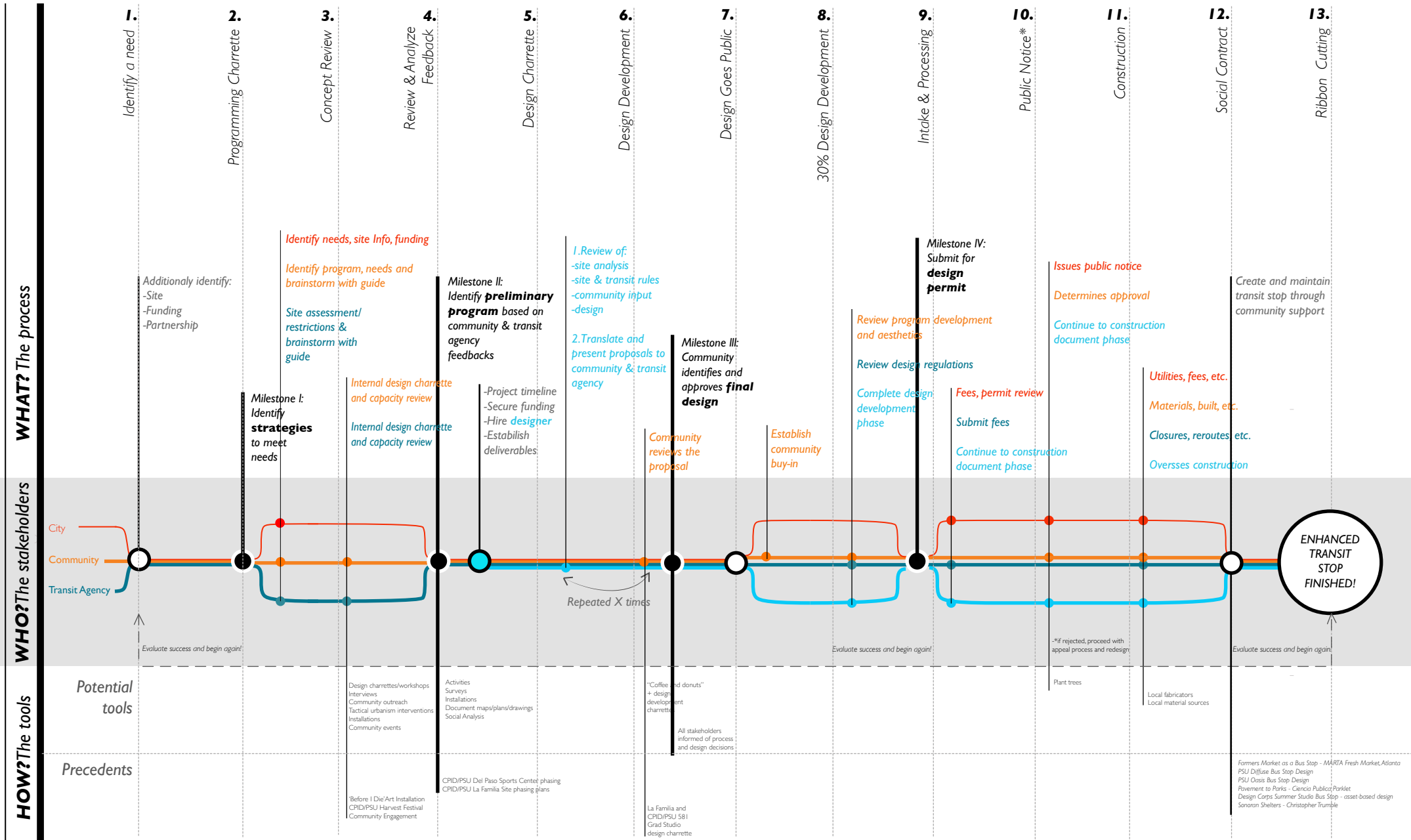

What are
basic
consider-
ations

when
beginning
bus stop
design

CHAPTER 2: TRANSIT STOP REGULATIONS AND POLICIES

Accessibility, safety and guidance are key elements for successful transit design. As gateways to the community, transit stops should be highly visible with clear signage, connected to non-transit amenities in safe and convenient ways, easy to find and comfortable to inhabit. This chapter outlines design fundamentals in order to give community groups a working knowledge of bus stop functionality as a baseline for developing proposals. Bus stop sizes and types, street-side location options for boarding and traffic needs, and design characteristics for platforms, shelters and amenities are presented, along with suggestions for community stewardship and involvement. These guidelines are intended to be used by community groups in conjunction with site analysis and rider and community needs assessments. Together, these tools support a more comprehensive approach to design that supports informed, effective community interventions, elevating the infrastructure from a technical solution to a placemaking opportunity.

2.1 Elements of a Bus Stop



Signage



Shelter



Shade



Branding

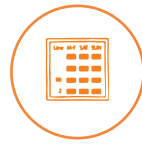

Information



Seating



Lighting

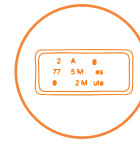

Real-Time



Tickets



Multi-line



Food



Bike and Car Parking



Shopping



Maintenance and Rest



ADA



ADA



Multi-line



Wi-fi



Greenspace



News & Book
Sharing



Maps



Security



Sustainability



Facilities





2.2 BUS STOP PARAMETERS

TYPES

SPACING AND LOCATION

DESIGN CHARACTERISTICS

AMENITIES AND CONCERNS

TYPES

The stop typologies start with the basic stop, which provides the essentials for accessibility, safety and guidance, and concludes with the end-of-line/terminus facility, which provides shelter services and amenities. The typologies are presented as an amalgamation of elements to encourage customization through mixing and matching.



ROLE OF THE TRANSIT STOP

ENCOURAGE RIDERSHIP

- Attract new riders
- Reduce stigma associated with mass transit by changing public perception of experience
- Install off-board fare payment system/equipment and wayfinding
- Provide amenities for pre-and post-boarding experience

IMPROVE ACCESS AND VISIBILITY

- Ensure safe, universal accessibility
- Promote visibility and facilitate branding of the system
- Enable passengers to board through multiple doors at level boarding

INCREASE SAFETY

- Provide passengers with a safe and secure environment by including such items as CCTV cameras, a public address system, public and security telephones, lighting and fencing
- Shelter from elements

SUPPORT COMMUNITY

- Capitalize on placemaking opportunities to transform transit stops into focal points within the community
- Increase connectivity with local businesses and organizations
- Create a sense of place within the community, encouraging program of activities to occur near the station or stop.
- Provide information about amenities within close proximity

IMPROVE SUSTAINABILITY

- Reduce emissions by increasing ridership
- Reduce travel needs by creating destinations in the community
- Sequester carbon and lower air temperatures by planting trees
- Provide stormwater remediation

SMALL, MEDIUM, AND LARGE SITES

SMALL

The absolute minimum bus stop site size, according to the National Association of Transportation Officials (NACTO), is 8' by 5' for boarding with a 2.5' clearing around a shelter (if a shelter is present).

MEDIUM

A medium site would include the minimum requirements (above) paired with a street that is designed with a larger sidewalk (10'-15') along the bus stop side.

LARGE

A large site includes the boarding minimums with potential programming room to grow into a lot or park nearby the bus stop.

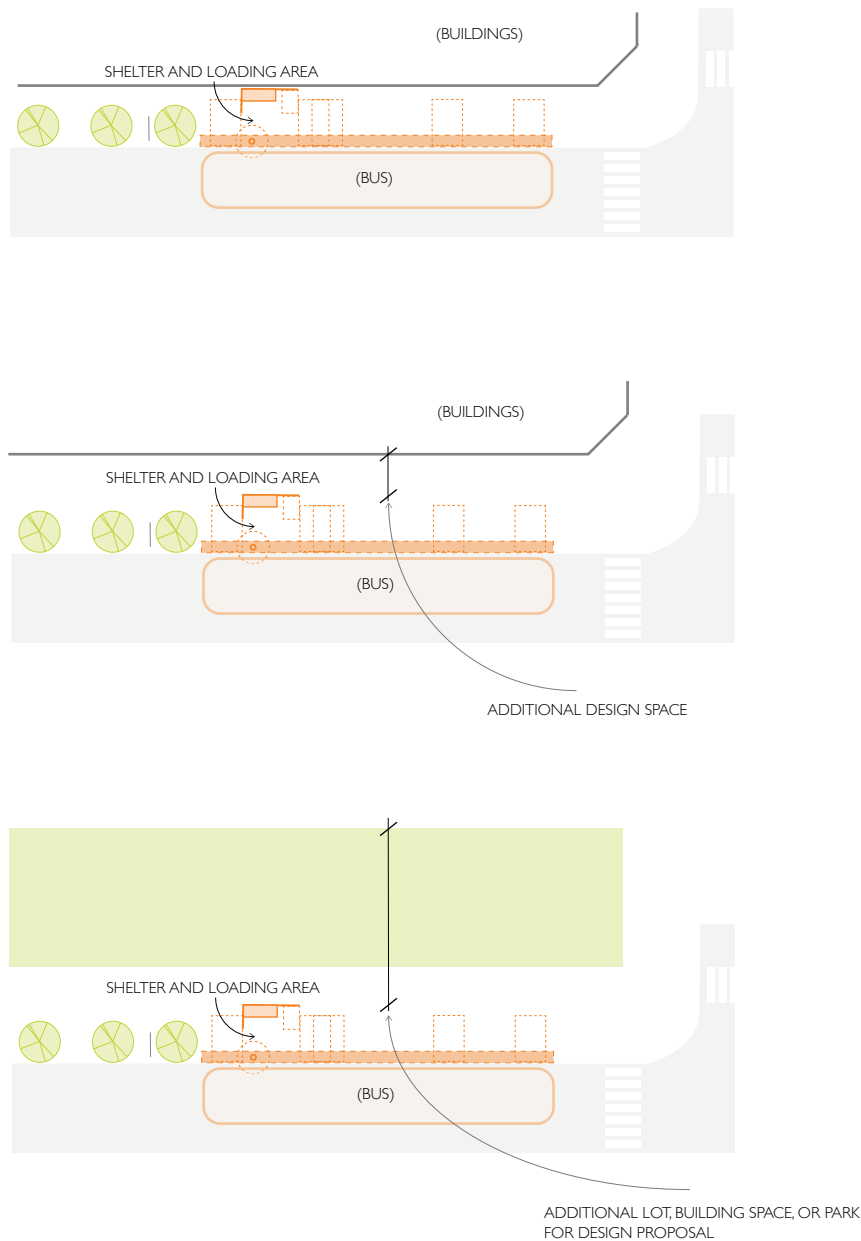

Example placement configurations adopted from the National Association of City Transportation Officials Transit Street Design Guidelines
<https://nacto.org/publication/transit-street-design-guide/station-stop-elements/stop-elements/small-transit-shelter/>

PLACEMENT

- 1 Shelters can be placed open to the curb, facing away from the curb, or at the building side of the sidewalk.
- 2 A 4' wide clear path is required and 5' is preferred along the entire length of the bus zone. 8'-12' is preferred in high traffic and commercial zones.
- 3 A 3' wide access path is required around station elements.
- 4 Shelters can be placed as close as 1' from the curb when oriented away from the curb, and 1' from the building facade when placed at the building side of the sidewalk.

Example placement configuration adopted from the National Association of City Transportation Officials Transit Street Design Guidelines <https://nacto.org/publication/transit-street-design-guide/station-stop-elements/stop-elements/small-transit-shelter/>

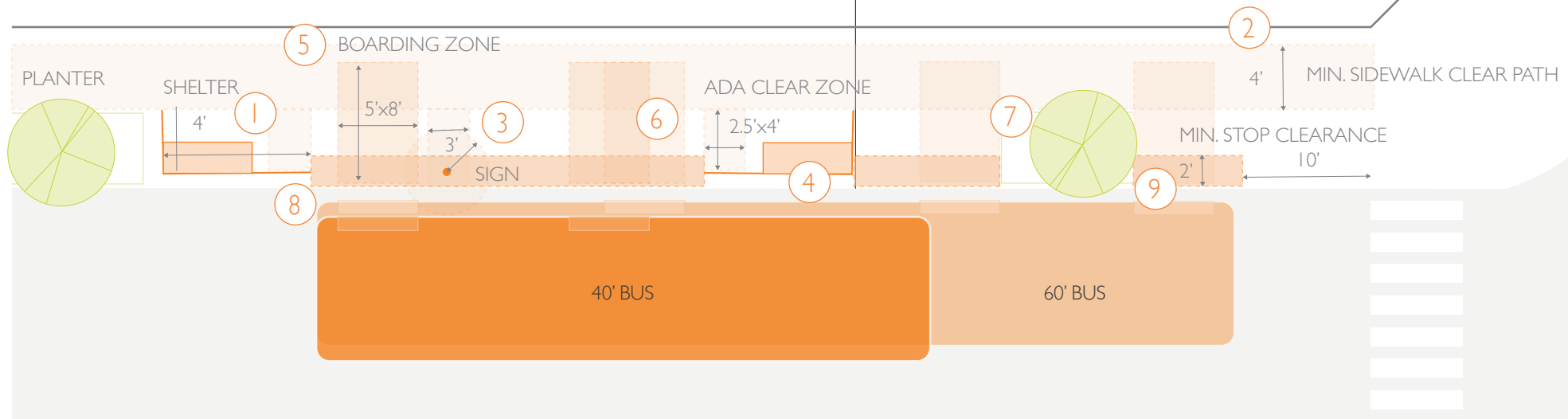

MINIMUM PLACEMENT GUIDELINES

- 5 The minimum unobstructed boarding area is 5'x8'. Placement depends on the length of transit vehicles and door locations. 8'-12' is preferred to account for this variation.
- 6 Shelter walls should not impede access paths.
- 7 Trees and planters can be installed in-line with shelters but cannot interfere with access paths or vehicle doors.
- 8 Shelter placement must not obstruct the line of sight of the passengers or driver.
- 9 Bus zones must have a 2' clear space at the curb.

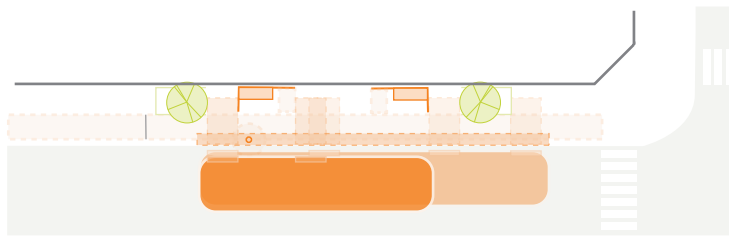

8-10' Sidewalk: Shelter and planters located at building facade

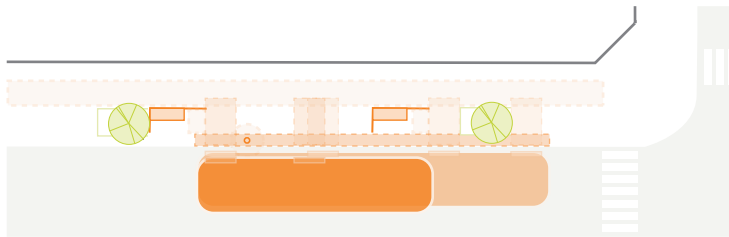

10-15' Sidewalk: Shelter and planters oriented to face curb

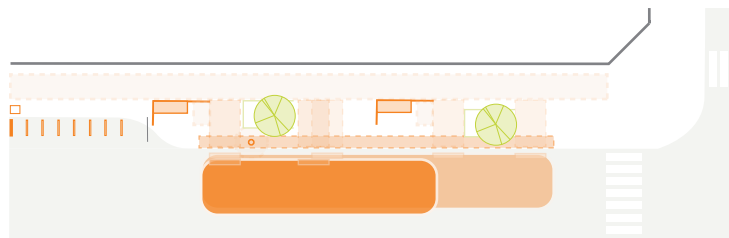

8' Sidewalk with Bus Bulb and Bike Share Station

Example placement configurations adopted from the National Association of City Transportation Officials Transit Street Design Guidelines <https://nacto.org/publication/transit-street-design-guide/station-stop-elements/stop-elements/small-transit-shelter/>

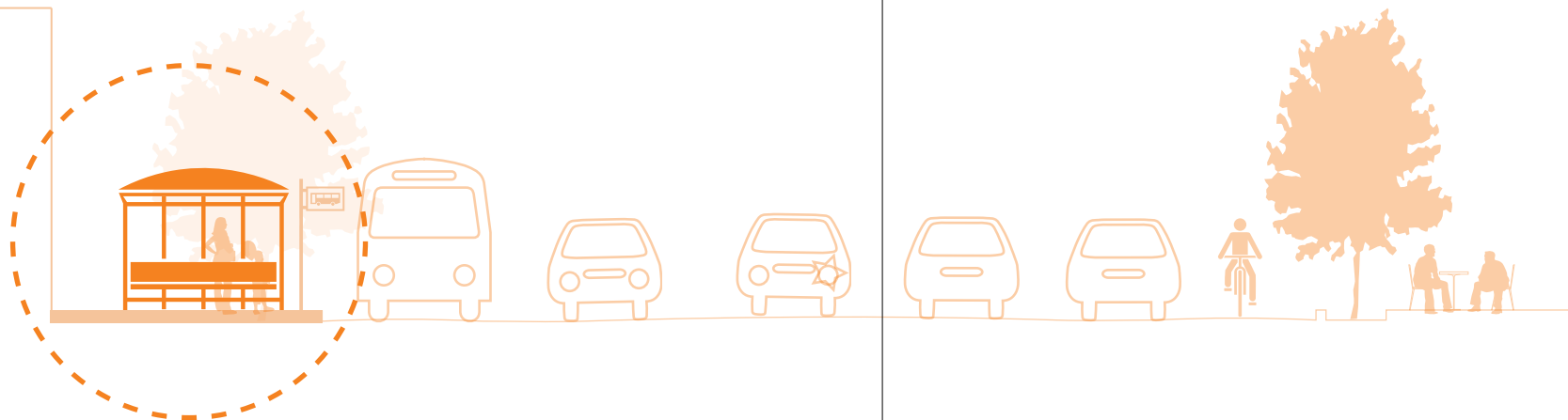

MINIMUM DESIGN GUIDELINES

MAINTENANCE

Shelters located adjacent to buildings should be placed at minimum 12" away from the building. Wall or other obstructions to allow for cleaning.

OBSTRUCTION

Shelters should not be placed so as to obstruct sidewalks or access to and from transit vehicles.

VISIBILITY

Shelters should not be placed where they obstruct visibility at street intersections or where vehicles exit onto an arterial from a private roadway or driveway.



KEY ELEMENTS



Signage



Shelter



Shade

BASIC STOP

In locations where space or budget are limited, a short term solution is needed, or the volume of service is low, the basic stop provides the key elements needed for a bus stop. Clear and visible signage for the pedestrian and driver and a shelter for passengers should be provided.

KEY ELEMENTS



Signage identifies service route and passenger waiting and boarding zones



Shelter protects passengers from the elements and provides a structure for amenities



Shade improves the immediate environment and waiting experience by reducing ambient air temperatures in the summer, filtering pollutants and beautifying the stop

WHEN TO USE

- Limited space and budget restricts options
- Too few riders will benefit to justify additional expense
- Short-term solution for new stops or staged stops

WAYS TO IMPROVE

- Add wayfinding signage for nearby community businesses, organizations and greenspaces
- Modify shelter panels with community art
- Partner with local business to provide trash service

KEY ELEMENTS



Branding



Information

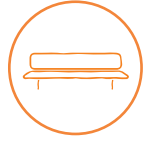

Seating



Lighting

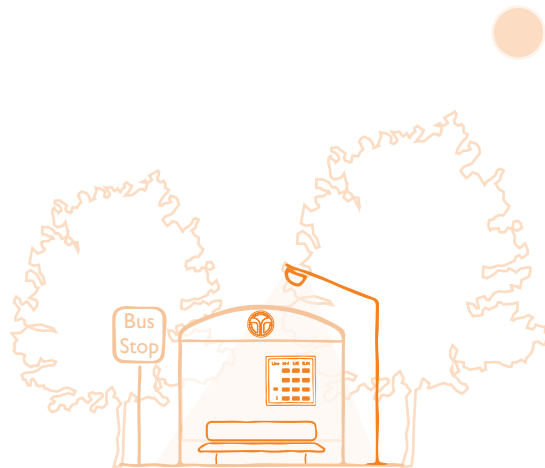

ENHANCED STOP

In locations where wait times are longer, a basic level of security is needed, or space is available for additional information, the enhanced stop builds from the framework of the basic stop. This is accomplished through lighting and seating to make wait times safer and more comfortable, additional information to provide assistance with route schedules and service notices, and branding to establish identity.

KEY ELEMENTS



Branding provides opportunities for supporting placemaking through visual mapping



Information such as schedules and service notices improve passenger experience



Seating provides respite for passengers with limited mobility and long wait times



Lighting improves passenger security and visibility at night

WHEN TO USE

- Basic stop is appropriate but requires more security and visibility

HOW TO IMPROVE

- Incorporate bike staples for secure bike parking
- Add a hydration station for health and sustainability
- Design lighting to avoid creation of an island effect



KEY ELEMENTS

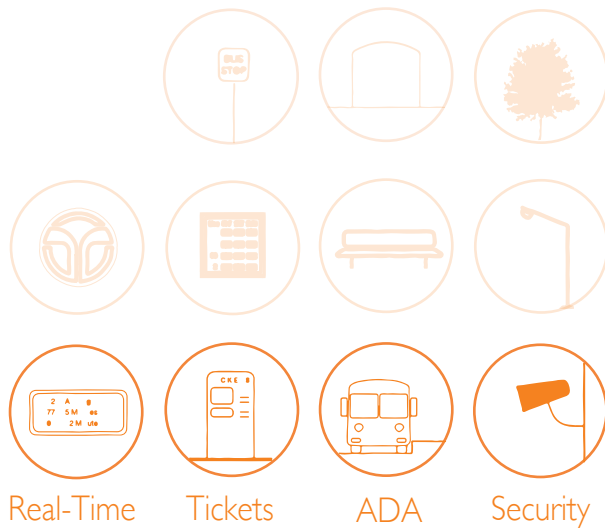

STATION

In locations where ridership is higher, service is more frequent, and improvements for accessibility and security are needed, the station stop provides elements that support these needs. Real-time info, fare collection machines, surveillance, and level boarding improve accessibility and safety.

KEY ELEMENTS



Real-time information provides riders with accurate wait times



Ticket machines facilitate purchasing fare with cash and credit card



ADA design of access and loading zones improves experience for those with limited mobility



Security systems foster sense of safety

WHEN TO USE

-Enhanced stop requires additional security and improved access

HOW TO IMPROVE

- Improve branding to include station name and identity for neighborhood



KEY ELEMENTS



Multi-line

Food

Bike and Car Parking

TRANSIT CENTER

In locations where lines of service overlap, transfers are common, and ridership is high, transit centers function as transportation hubs and offer amenities and services for riders that support the convenience of mass transit and reduce commuter hassles. Food and commercial services provide necessities for passengers waiting to board and waiting to transfer.

KEY ELEMENTS



Multi-line service connects transit center to multiple districts



Food, beverage and convenience services support comfortable transition times for passengers



Bike and car parking facilitates multiple park-and-ride options for passengers

WHEN TO USE

-Where lines of service intersect, transfers require wait times, or stop serves as a park and ride. High travel demand, available space, and budget support a larger station with more amenities.

HOW TO IMPROVE

- Increase trash service to keep area clean.
- Encourage travel between districts by providing district branding and information
- Provide space for local small business incubation.

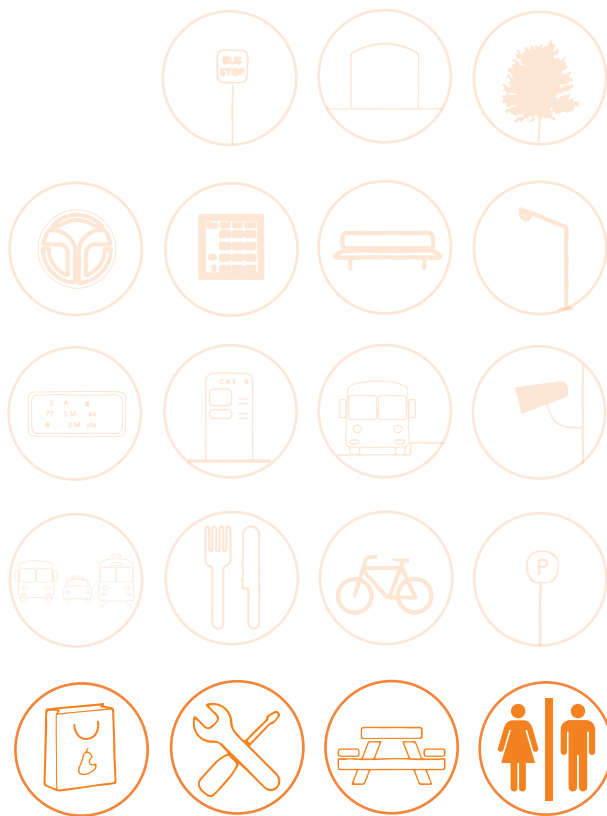
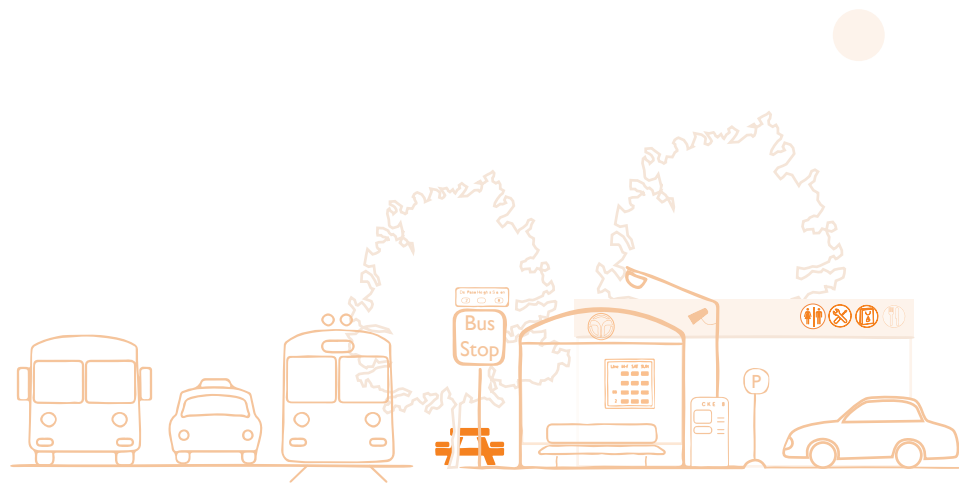



KEY ELEMENTS

Shopping Maintenance and Rest Facilities

END-OF-LINE/TERMINUS FACILITY

KEY ELEMENTS

-  Shopping
-  Maintenance
-  Rest Area
-  Facilities

-Includes all elements of an enhanced bus stop while taking advantage of the additional services that better the user experience.

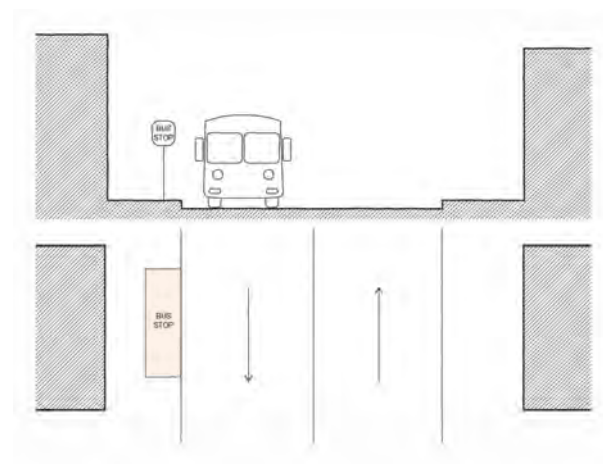
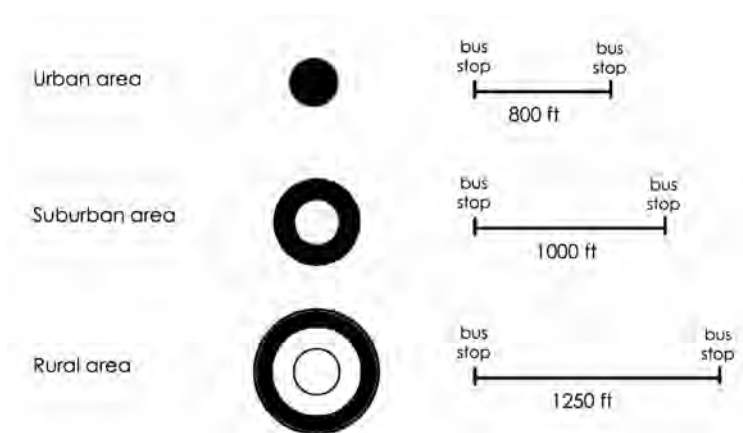

SPACING AND LOCATIONS

SERVICE AREA SPACING

There are a variety of options for bus stop placement in relation to traffic lanes and intersections. These locations affect pedestrian access to the stop as well as rider access to non-transit amenities. The location and immediate environment of the stop determine access. Safety and connection to community can encourage or deter ridership. The positioning of the stop also impacts the bus's relation to surrounding traffic and the ease of entering and exiting the stop. Common positions, with advantages and disadvantages, are listed below.

Spacing of service stops is related to proximity to urban center. Distance between stops ranges from 800 feet in urban centers to 1250+ feet in rural areas.

CURBSIDE STATION/STOP

ADVANTAGES

- Space on sidewalk
- No use of street space
- Traffic crossing not required

DISADVANTAGES

- Use of curb lane to provide stopping space
- Required for each direction of travel
- Sign visibility easily obstructed by trees and buildings
- Limited space for design intervention

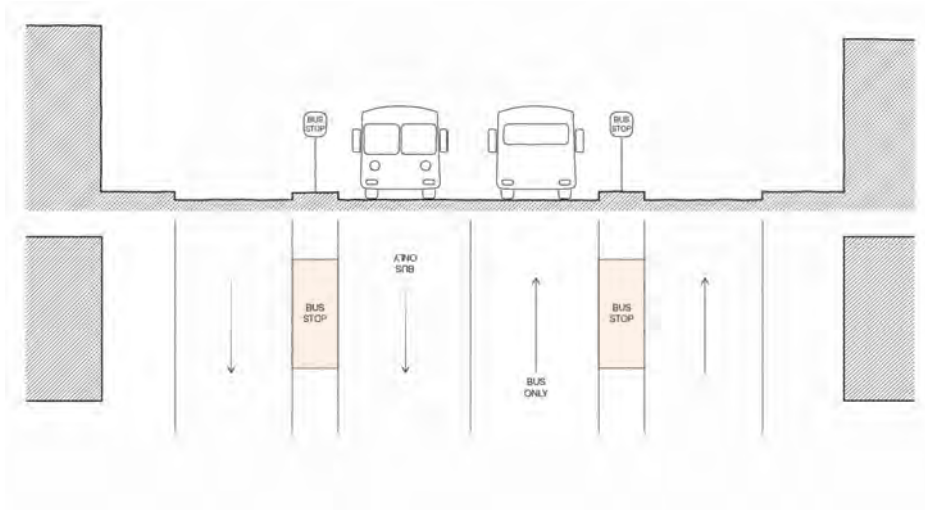

MEDIAN - SIDE PLATFORM

ADVANTAGES

- Minimum conflict
- Better visibility for bus drivers
- No visual obstruction to businesses

DISADVANTAGES

- Uses street space
- Requires unique signal
- Traffic crossing required
- Limited space and difficult maintenance

MEDIAN - CENTER PLATFORM

ADVANTAGES

- Shared passenger facility
- Single platform serves both directions
- Reduces cost

DISADVANTAGES

- Requires vehicles with left side doors
- Complicates left turns and road sharing

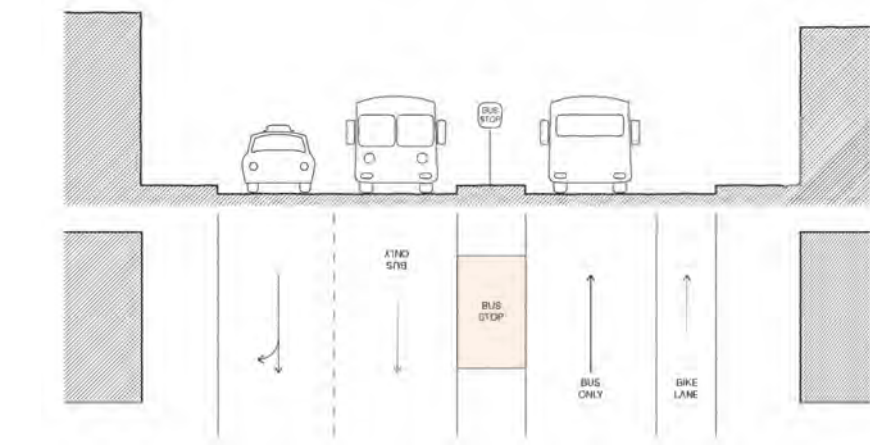

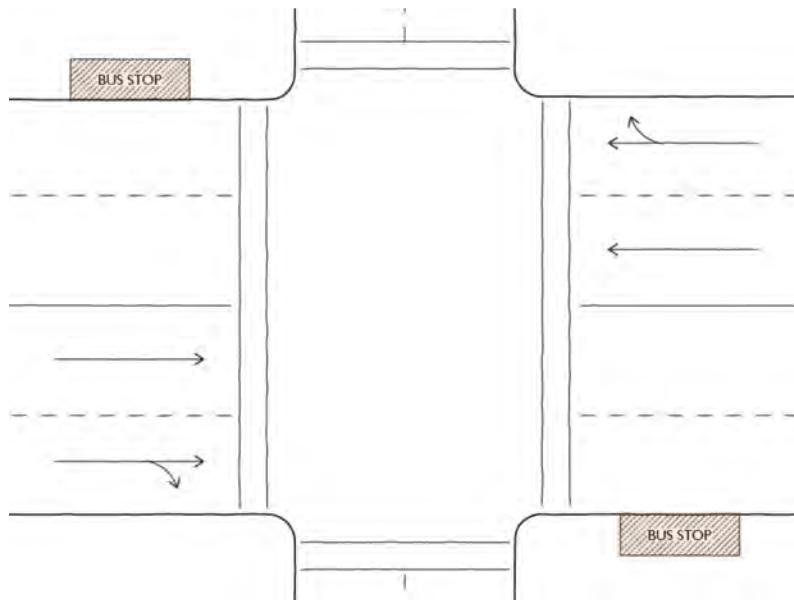
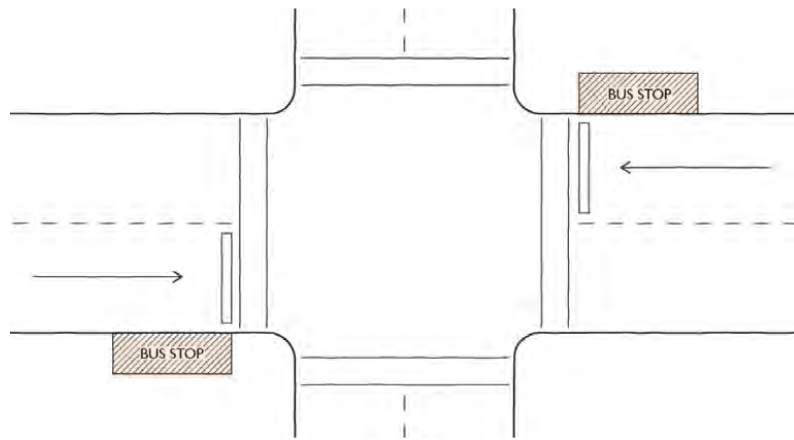

NEAR SIDE - BEFORE INTERSECTION

ADVANTAGES

- Vehicle arrival is independent of traffic signal timing
- Reduces the walking distance from the intersection

DISADVANTAGES

- Minimizes the use/benefit of transit signal priority
- Departures delayed by the traffic signal cycle

FAR SIDE - AFTER INTERSECTION

ADVANTAGES

- Improves travel time if signal priority is used
- Does not impact the right turns of other vehicles
- Aligned with the left turn lane

DISADVANTAGES

- Buses may stop twice at an intersection
- Bus stop may have to move far beyond the intersection to allow for the accumulation of several vehicles

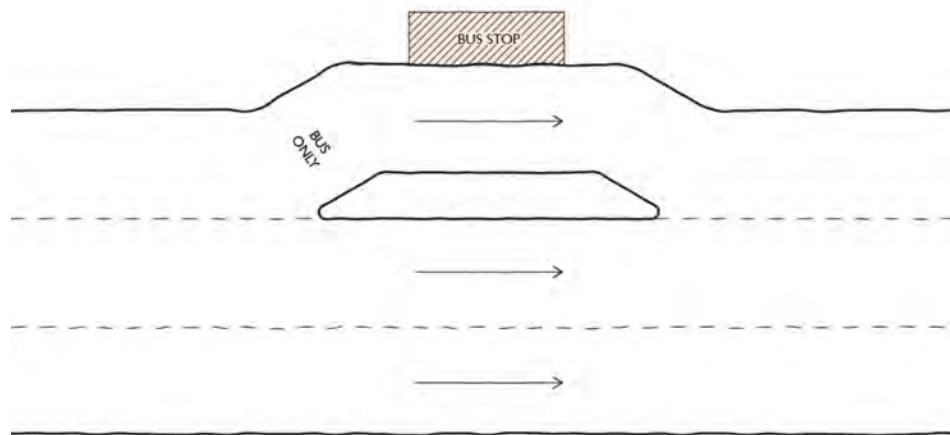
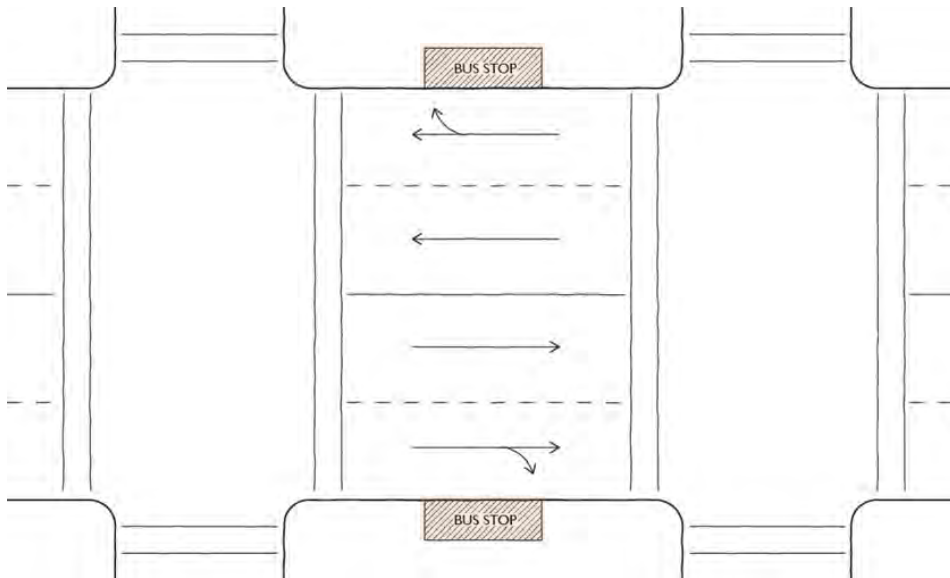

MIDBLOCK

ADVANTAGES

- Independent of traffic signal timing
- Vehicle staging space between platform and traffic signals

DISADVANTAGES

- Pedestrian safety risk if there is no crosswalk

OFF-STREET

ADVANTAGES

- Eliminates conflicts with other vehicles/riders
- Designated space expresses intentionality/importance of stop in streetscape
- Opportunities for additional amenities

DISADVANTAGES

- Potential for low visibility
- Additional security measures may be required
- Additional operating costs
- Increasing running time to access station

Area: $P_{max} \times (\text{ft}^2 \text{ per passenger}) + A_{inf}$



(10-13ft²) - Spacious and easy to move



(2-3ft²) - Crowded and uncomfortable

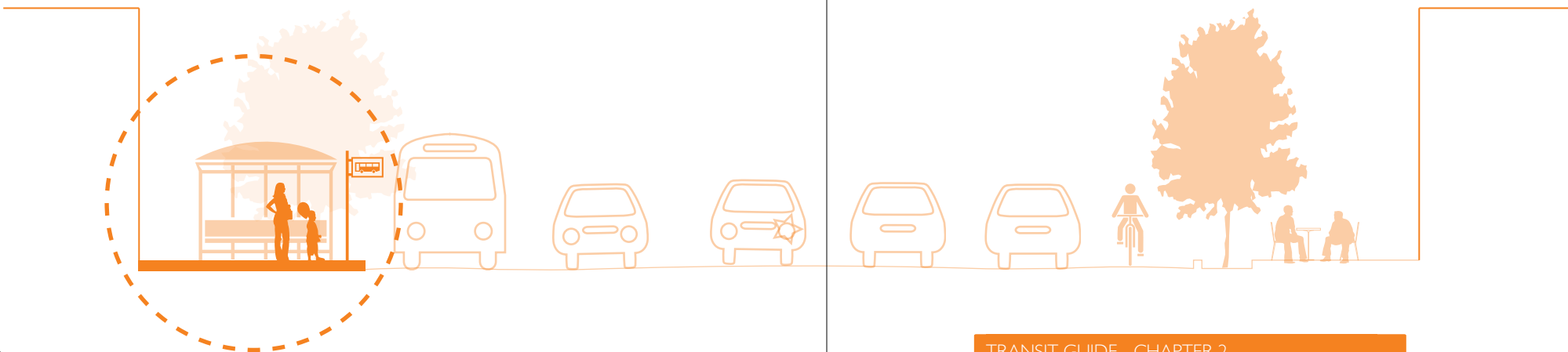

DESIGN CHARACTERISTICS - PLATFORM

This section addresses circulation, passenger volume, accessibility, orientation and boarding considerations for stops with platforms.

PLATFORM AREA

Comfort level of riders, both on and off the bus, is directly affected by the proximity of other riders. To support a positive user experience, determine the estimated volume of riders at peak hours. Calculate the platform area by multiplying the maximum number of passengers (**P_{max}**) by the desired square footage per passenger, plus the area required for infrastructure (**A_{inf}**).

KEY FACTORS

- Passenger circulation for arrival and boarding
- Passenger waiting area
- Space available at the site
- Expected volume of riders
- Service frequency
- Accessibility

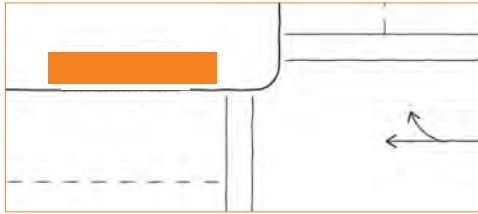

115 ft - Farside stops (right turn permitted at intersection)

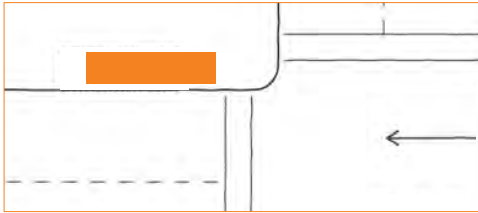

90 ft - Farside stops right turn not permitted at intersection

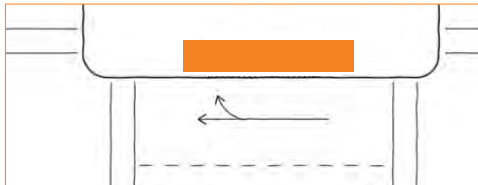

150 ft - Midblock stops

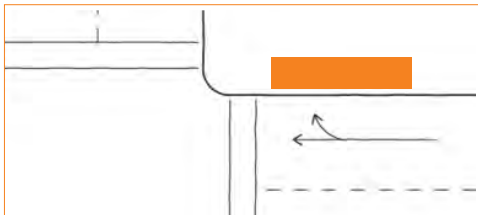

105 ft - Nearside stops

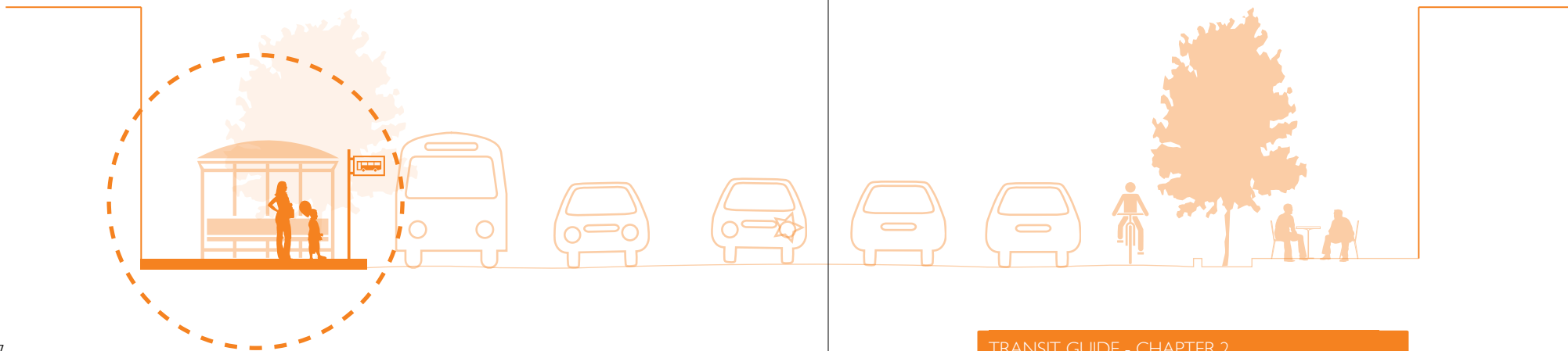

PLATFORM LENGTH

Platform length is determined by the required loading capacity, the location of the stop in relation to traffic, and the maneuvering space required for the bus. Platform length is also informed by accessibility requirements and existing grade

LOADING CAPACITY

The number of buses that a stop will accommodate simultaneously in a 20 minute peak period determines the loading capacity.

TYPE OF STOP

Location of the platform on the block dictates the length of the platform. Farside stops require the smallest platform while midblock stops require the greatest length.

MANEUVERING SPACE

The maneuvering space requirements of buses to enter and leave a stop plays a role in determining platform length.

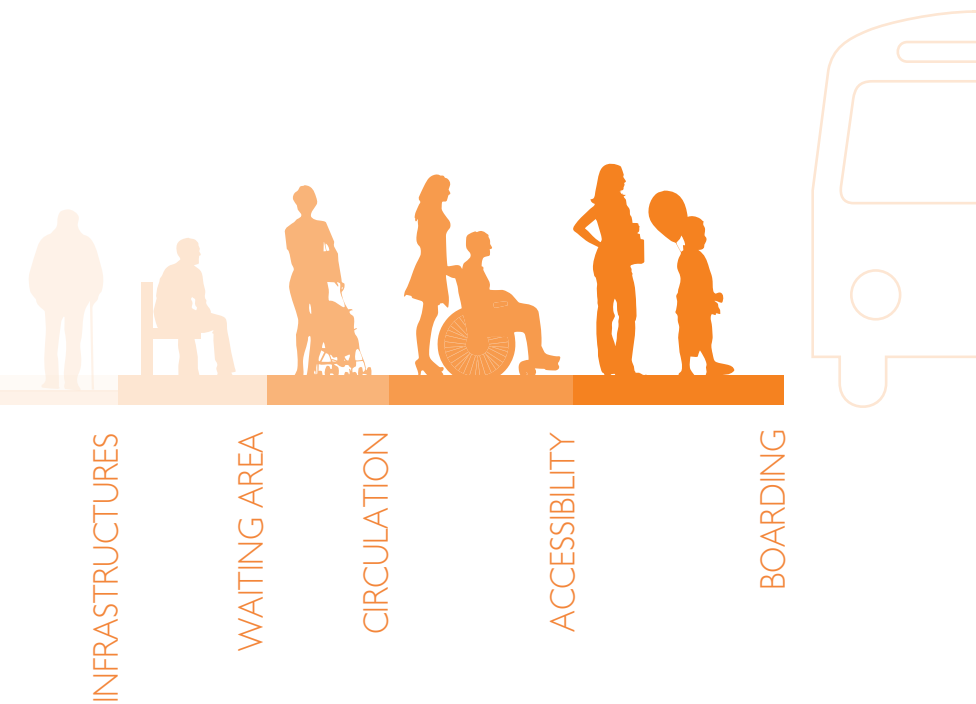

PLATFORM WIDTH

Platform width is set to accommodate station infrastructures, waiting areas, circulation areas, and ADA passage. Widths are constrained by existing property lines and buildings, as well as the width of the existing sidewalk, making fully accessible stops one of the biggest challenges.

INFRASTRUCTURES

Width required for stairs, ramps, elevators, ticket vending machines, bike racks, etc.

WAITING AREA

Width required for passengers waiting for a vehicle to arrive

CIRCULATION

Width required for passengers to circulate for entering/exiting

ACCESSIBILITY

Width required to ensure access for passengers with disabilities

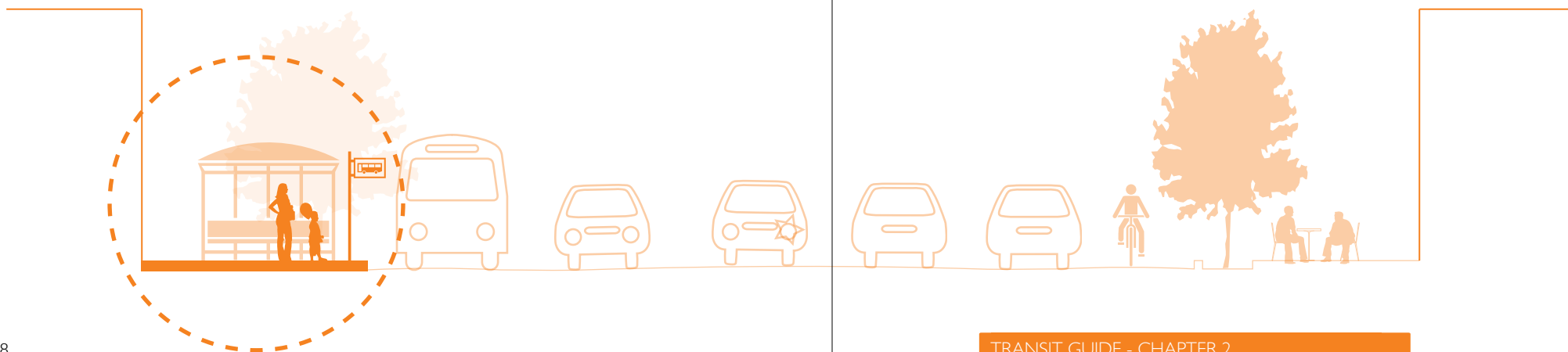



PLATFORM HEIGHT

CURB HEIGHT

Standard Curb - Vertical gap requires deployable ramp or low floor buses for full accessibility, increasing dwell time and increasing equipment costs

Raised Platform - Reduced vertical gap decreases dwell times
Height of platform requires additional space for access ramps

Level or Near-Level Boarding - Most passenger friendly boarding experience. Requires the most additional space for access ramps

BOARDING AREA SLOPE

The bus stop boarding area slope must correspond to the directional slope of the street. The slope from the sidewalk to the boarding edge of the platform cannot exceed 1/48"

PAVEMENT

Free-standing shelters should be placed on a non-slip concrete pad, 12ft x 7ft (min) sloped (2%) toward the roadway for drainage

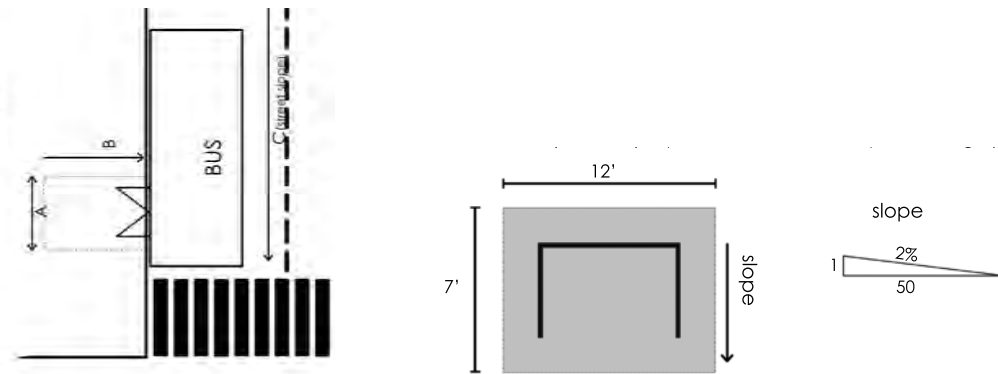

- A: Boarding area length slope
- B: Boarding area width slope
- C: street slope

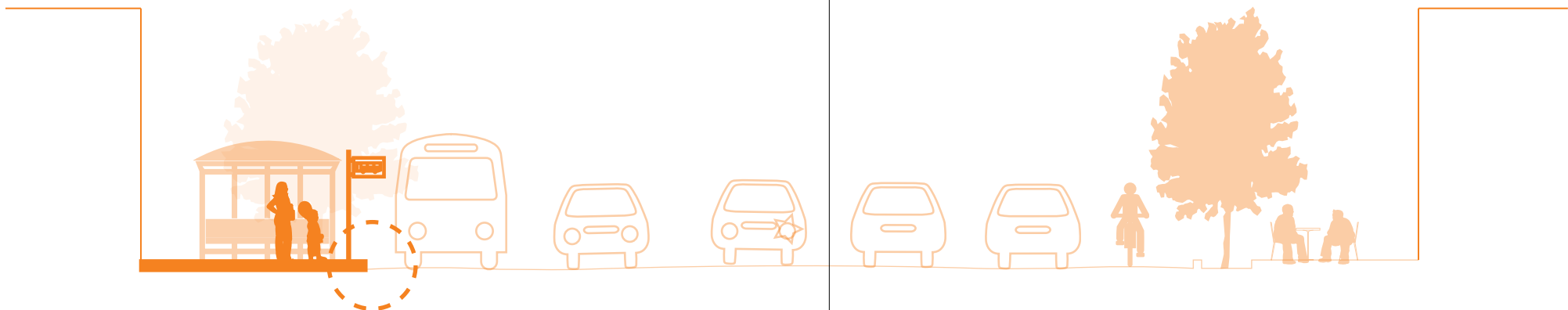

DESIGN CHARACTERISTICS - SHELTER

Shelters play a key role in passenger comfort during waiting periods and provide many opportunities for branding, place-making and community expression. Shelters also lay claim to specific areas of the right of way as an extension of the service provided by the transit authority. When shelters create a positive visual and experiential connection, they elevate the status of waiting spaces for riders in the hierarchy of the street. This section provides minimum placement and design guidelines addressing location, material choice and design of the structure for maintenance, visibility and clearance requirements, as well as safety and accessibility.

GENERAL

- Provide consistency among all stations, distinction from other system bus stops and connection to the branding.
- Use shelter design to enhance visibility of the service.
- Provide consistency (in materials, colors and design) with other site elements, including lighting, railings, litter receptacles, bike racks, etc.

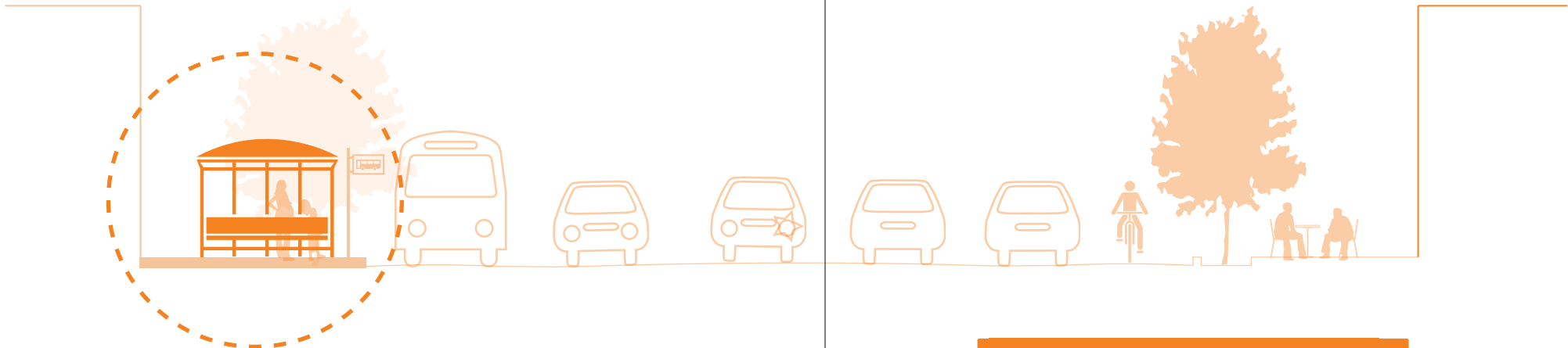

MINIMUM DESIGN GUIDELINES

MATERIALS AND STRUCTURE

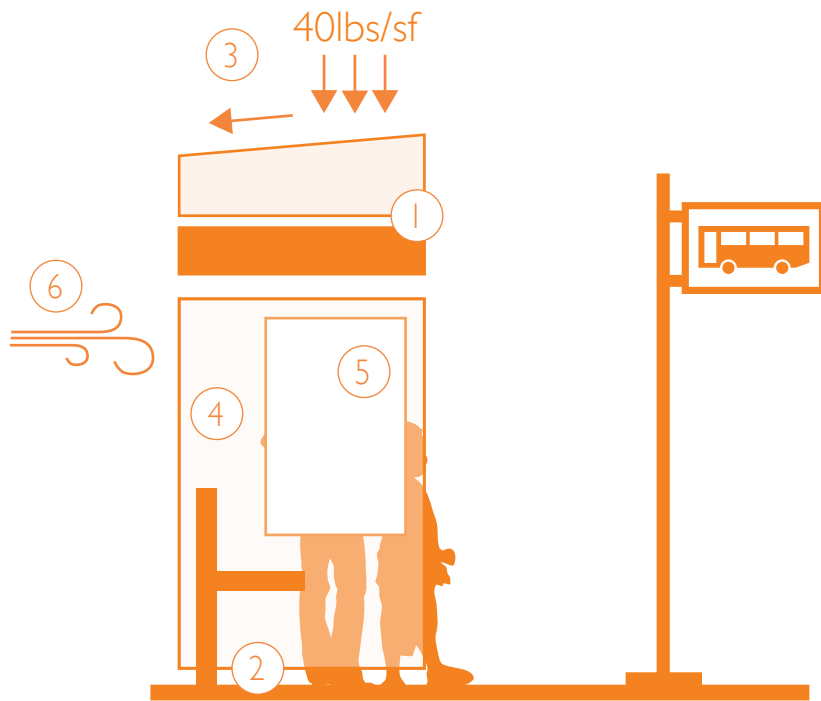

- 1 Bus shelters should be constructed with weather and vapor resistant materials (i.e. brick, metal, tempered glass, etc.) that are easy to maintain, replace and remove. Translucent roof panels should be considered for ambient light.
- 2 Shelters should have an opening from grade to the bottom of the wall panel of at least 6" for ventilation, prevention of trash accumulation, and drainage.
- 3 Roof and support structure of the shelter should be designed to hold a load of 40lbs/sf and designed so that drainage is sloped away from the street side of the shelter.
- 4 Transparent vertical panels on the side of the approaching vehicle are required.
- 5 Shelter structure should accommodate the placement of advertising, art or information panels within or in place of some vertical panels.
- 6 Orientation of vertical panels to protect from prevailing winds and wind-driven rain is preferred.

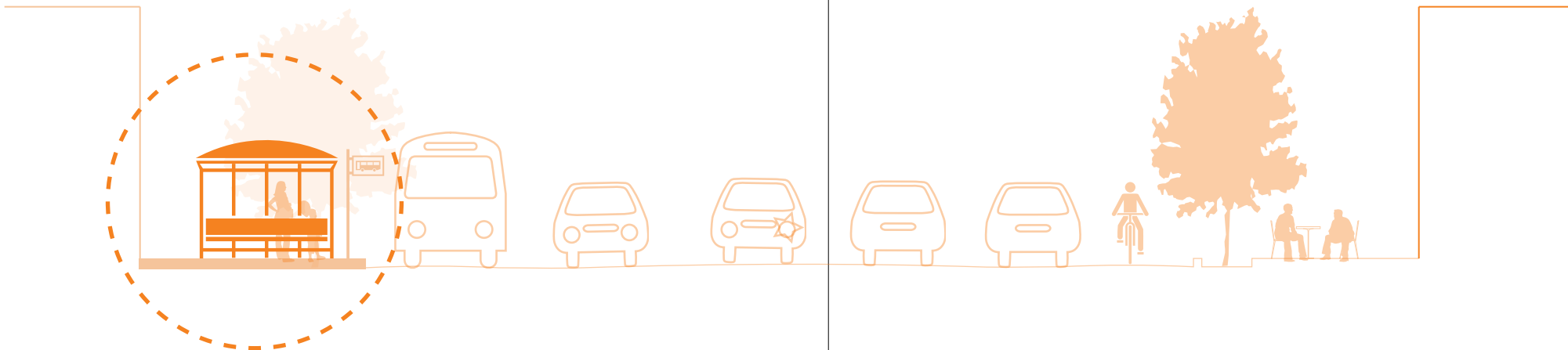

OPEN

Pole or cantilever shelters fit narrow sites, protect from rain and sun, and provide space for leaning rails.

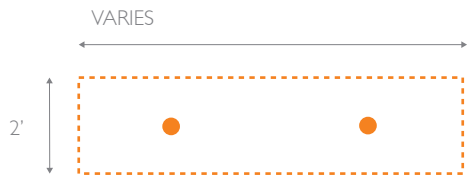

TWO SIDED

Two sided shelters also protect from wind while maintaining open sightlines and easy access. Place in front of and open to loading zones as close as 12" from the curb.

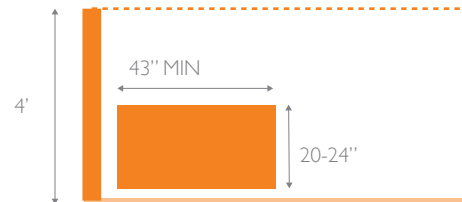

THREE SIDED

Three sided shelters provide protection from storms but require more clear space for accessibility.

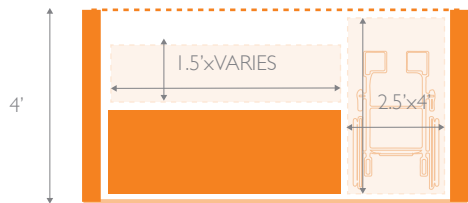

FOUR SIDED

Fully enclosed shelters are useful in cold climates, but they must be 5' deep for accessibility and set back from the curb.

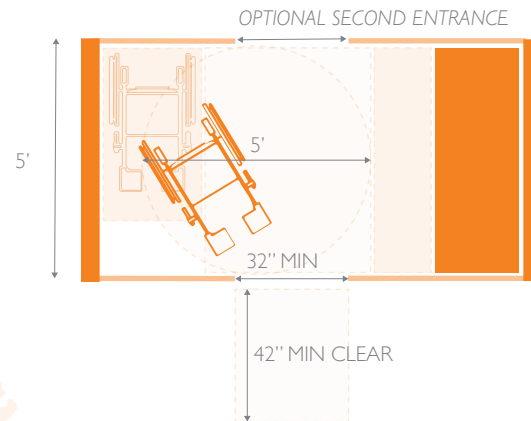

MINIMUM DESIGN GUIDELINES

AREA

-Minimum should be based on 10sf coverage area per passenger.

ACCESSIBILITY

- Minimum clearance of 4ft (preferred 8ft) from the front, sides and rear for free-standing shelters to provide for wheelchair access
- Minimum interior area of 2.5ft by 4ft for full ADA accessibility.
- If the space is limited, a minimum area of 5ft by 8ft shall be provided to the side of the shelter where the wheelchair accessible door is located on the vehicle.





AMENITIES AND CONCERNS

The following is a list of additional design elements to enhance the accessibility, safety, comfort and visibility of the stop as well as its role in wayfinding and branding for the neighborhood. Amenities and design elements that address concerns are presented as "a-la-carte" to encourage mixing and matching based on the needs of the specific location.

REAL TIME INFORMATION

- Providing real time information of current status of bus operations eliminates the feeling of uncertainty for transit users.
- Alternative: real time information through cell-phones/ applications.

MAPS

- Maps and other wayfinding devices help riders who have just arrived to orient themselves with the area surrounding the station.
- Way-finding can be comprised of special signage, signage on the pavement, as well as signage through digital means
- Integration of design elements and way-finding can be a creative application of station art.

LIGHTING

- Station lighting provides: sense of security, illumination, station location identification, aids bus operators in determining whether passengers are waiting to board.
- Attractive station lighting highlights station's architectural and design elements, which enhance the rider experience and the appeal of the station for the community.
- Lighting also communicates when the station is closed, (by changing the color and intensity of the lighting when the station is closed.)



AMENITIES AND CONCERNS

TRASH AND RECYCLING

-Trash and recycling receptacles are necessary to minimize litter at stations and on buses, as many riders have food and drink containers and other items to dispose of before boarding the vehicle. Clean space encourages ridership and quality of transit experience.

NEWSPAPER AND BOOK SHARING

-Placement of newspaper vending boxes or book sharing solutions addresses the desire of many transit users to read while waiting for a bus or traveling.
 -The benefits of having newspaper vending boxes must be balanced against security concerns.

WIFI

-Providing a wifi connection improves the experience of the user. Wifi connection helps the user pass the time at the bus stop and provides access to service information such as schedules, delays, routes and real time information, etc.

LANDSCAPING

-Landscaping should be attractive and blend in well with the local environment. It should be designed to make the stop a comfortable and desirable place to be.
 -In order to minimize maintenance costs, native species requiring minimal watering should be used.
 -Improves air quality
 -Plant trees!



AMENITIES AND CONCERNS

BIKE LOCKING LOCATIONS

- Placement of bicycle facilities should be near areas with high volume of pedestrian activity in order to promote usage and security, but should not interfere with pedestrian circulation.
- New stations should be designed with space for expansion of at least 40 enclosed bicycle locker spaces to allow for future demand.
- Each bicycle locker should allow for a 2ft x 6ft space per bicycle for storage, and 2ft along the width and 5ft along the length for access.

SUSTAINABILITY

- The design of the bus stop should be developed keeping in mind sustainability concepts. Recycled materials and considering the climate site conditions by installing appropriate solutions such as solar panels, rain catchment systems, and vertical wind protection panels becomes essential.

SECURITY

- A balance between crime prevention and attractive and comfortable solutions should be kept in mind.

*Useful guidelines: Crime prevention Through Environmental Design (CPTED)

ACCESSIBILITY

- Bus stop designs have to take into consideration regulations and standards for persons with limited mobility.

*Useful guidelines: ADA standards for Transportation Facility by the Department of Transportation.



CONCERNS

BRANDING

-Branding gives a service or product a distinct identity that results in clear and positive public recognition of the service.

-Elements of the station branding can be included within the actual design of the station components (e.g. shapes and sizes) or included on all structures, customer information panels and amenities at the station with colors, logos, or graphics.

MANTENANCE

-Design should include elements that help reduce maintenance.

-Stainless steel railings can be self-polishing.

-Minimizing vertical surfaces can reduce graffiti, posters and other unwanted markings.

-Space for maintenance activity, maintenance vehicles and materials should be considered in the design.

-Consideration should be given to ensuring that service vehicles can access stations and stops and park near them, if required.

CONTINUITY VS. DISTINCTION

-Bus stops should have unified standard design elements that create visual continuity. At the same time, they should leave space for community or district branding and identity.

-A good balance between these two aspects should be considered when designing a bus stop.

BIKE SHARE DESIGN GUIDELINES

SITING CRITERIA

Bike share locations should be accessible and convenient. They should be easy to maintain and restock, improve the surrounding pedestrian environment, and not interfere with more important elements of the street scape, such as utilities, loading docks, and transit stops.

One important question when considering placement is how the bike share station can provide a buffer for pedestrians while also providing a place where users feel comfortable dismounting, docking and locking bikes. For example, one aspect to consider is visibility. Is the bike share located adjacent to a right-hand turn lane? Drivers turning corners can be distracted by oncoming traffic and concerned with merging. They might also cut the corner or fail to slow down when making the turn. It is critical to examine traffic patterns to determine what safety measures should be taken. A design solution to this issue could be to extend the pedestrian right of way at that location by extending the sidewalk to form a bus bulb, or adding a bioswale to buffer the bike share station.

ON-STREET SITE CLEARANCES

- 1 4' from bus zone and parking space
- 2 60' from bus zone sign
- 3 3' from crosswalk, driveway and stop, advance stop or yield bar
- 4 6" from curb - stations should be oriented to face the curb
- 5 5' from fire hydrant
- 6 3' from corner storm drain or 25' from mid block drain
- 7 Bike share advert panel to be located at furthest end from intersection
- 8 Payment Kiosk oriented to face curb
- 9 3' from utility covers
- 10 3' spacing between staples
- 11 4' docking clear space required behind station

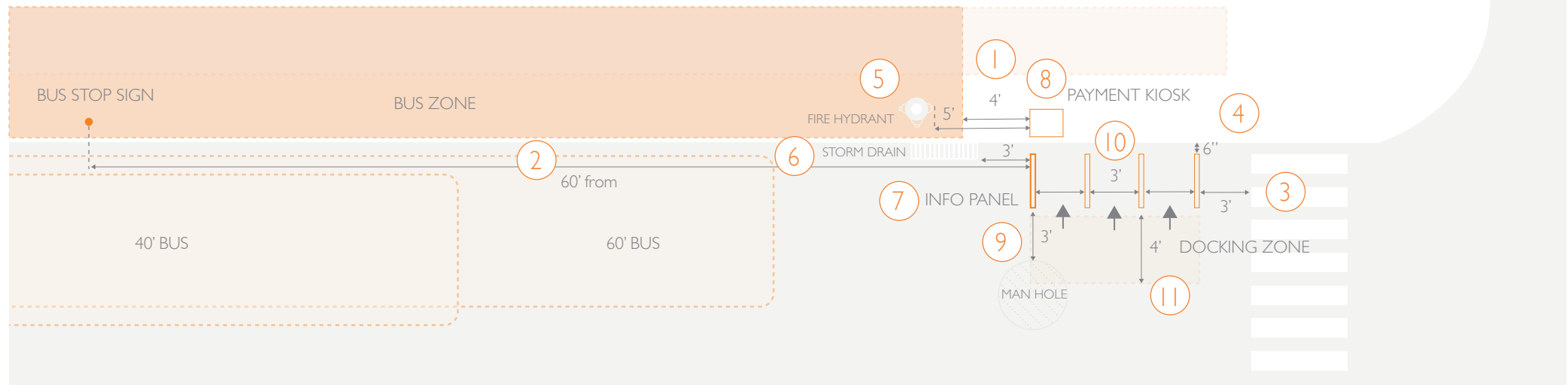

*How do you
insert*

***place
making***
*into
bus stop
design*

CHAPTER 3: PLACEMAKING

The incorporation of placemaking into a community supports community identity and investment. A place that provides amenities for social, economic, and cultural interactions, in turn, supports the identity of a city at large. Bus stops provide opportunity to create place through a variety of design interventions. A bus stop becomes a place of gathering, a small business incubator, or a work of art through careful consideration of its surrounding community and their aspirations. The following precedents demonstrate successful forms of placemaking that serve as inspiration for the design of bus stops.

PRECEDENTS

I. FORT COLLINS TRANSFORT BIKE-N-RIDE

TransFort/City of Fort Collins Transportation includes the bicycling community in their transportation system designs.

<http://www.ridetransfort.com/abouttransfort/bike-n-ride>



KEY ELEMENTS:

Street design considers transit, cyclists, and pedestrians.

Bike-n-ride stops support healthy living through alternate modes of transportation.

Cycling storage and amenities can be incorporated into existing transit lines as a means of improvement and maintenance plans.

FACTS:

Location: Fort Collins, CO, U.S.A.

Designer: Fort Collins City Plan

Cost/Funding: Transfort/City of Fort Collins Transportation

Maintenance: Transfort/City of Fort Collins Transportation

APPLY THIS TO A BUS STOP DESIGN:

CONSIDER A BIKE-N-RIDE AS A BUS STOP:

-if the community desires a bike path or supports an existing bike path as an important community asset (see Ch. 2 for 'Bikeshare Design Guidelines')

-if the transit agency is looking to incorporate cyclists into their transit lines (bikes on bus, trains, storage at stops, etc.)

-if there is adequate space to build a bike storage unit

-if there is adequate space to install additional bike racks

*See Transit Guide Chapter 2 for design dimensions, rules and regulations. Refer to your city's existing codes and regulations for adjusting guidelines.

PRECEDENTS

2. ATLANTA FRESH MARTA MARKET

“The Fresh MARTA Market is a pop-up farm stand that takes place in four MARTA public transport stations. The goal is simple: help farmers sell more produce while getting healthy, fresh food into places where people already are.”

<http://cfmatl.org/marta/>



KEY ELEMENTS:

The market sustainably partners local business with an existing transportation:

Community Farmers Markets, GA Food Oasis - Atlanta, Atlanta Community Food Bank, Organix Matters, MARTA

The market provides access to healthy food and living at multiple locations across Atlanta, GA.

FACTS:

Location: Atlanta, GA, U.S.A.

Designer: n/a

Cost/Funding: Community Farmers Markets (CFM)

Maintenance: Community Farmers Markets (CFM) and MARTA

APPLY THIS TO A BUS STOP DESIGN:

CONSIDER A MARKET AS A BUS STOP:

- if the community has limited access to fresh food (i.e. food desert)
- if the stop has adequate space for large gathering and/or community events (see Ch. 2 for 'large site' dimensions)
- if the neighborhood has existing community supported agriculture, gardens, local businesses, or vendors that need space to gather and sell their goods

*See Transit Guide Chapter 2 for design dimensions, rules and regulations. Refer to your city's existing codes and regulations for adjusting guidelines.

PRECEDENTS

3. BEFORE I DIE

Before I Die is a participatory public art project that allows neighbors to reflect on aspirations and learn about one another through a shared activity.

“Before I Die is a global art project that invites people to contemplate death and reflect on their lives. Originally created by the artist Candy Chang on an abandoned house in New Orleans after she lost someone she loved, today there are over 2,000 walls around the world.”

www.beforeidie.city/about



“... My hope is that with this wall we can find some kind of hope and positive confrontation of grief by realizing that we are not alone in this feeling, that there are many others willing to listen.”
-Erika Nj Allen

KEY ELEMENTS:

Opportunity for creative engagement with community to provide feedback about goals and identified needs.

This project provides an opportunity to learn about the people that create a community or city.

FACTS:

Location: global - original: New Orleans, LA, U.S.A

Designer: Candy Chang

Cost/Funding: donors - see www.beforeidie.city/about/donors

Maintenance: 'Before I Die' project participants

APPLY THIS TO A BUS STOP DESIGN:

CONSIDER A 'DIALOGUE BOARD' AS A BUS STOP:

-if the neighborhood would benefit from a chance to vocalize their needs for an existing stop or desires for a potential new stop

-if the transit agency or funding organization wants to establish community support for a new bus stop project

*See Transit Guide Chapter 2 for design dimensions, rules and regulations. Refer to your city's existing codes and regulations for adjusting guidelines.

PRECEDENTS

4. SEATTLE KING COUNTY METRO

“In 1989, Metro started a unique program to involve youth and other members of the community in designing and painting bus shelter murals. Metro contributes panels and paint, and members of the community donate their artistic talent to create murals for Metro bus shelters.”

*<http://metro.kingcounty.gov/prog/sheltermural/>



KEY ELEMENTS:

Each mural is community supported and designed.

Local schools, artists, and organizations design and fabricate the murals for the existing bus shelters.

*see website for guide/proces

FACTS:

Location: Seattle, WA, U.S.A.

Designer: a variety of artists and volunteers

Cost/Funding: King County Metro

Maintenance: King County Metro

APPLY THIS TO A BUS STOP DESIGN:

CONSIDER A MURAL DESIGN FOR A BUS STOP:

- if an existing stop needs repair and renovation
- if funding for a local artist/art project is presented
- if a community organization, school, or artist is seeking a design-build opportunity

*See Transit Guide Chapter 2 for design dimensions, rules and regulations. Refer to your city's existing codes and regulations for adjusting guidelines.

PRECEDENTS

5. PAVEMENT TO PARKS - Ciencia Pública: Agua

"A Parklet is a new type of Pavement to Parks Project. Instead of reclaiming a piece of underutilized roadway at an intersection, Parklets repurpose two to three parking stalls along a block as a space for people to relax, drink a cup of coffee, and enjoy the city around them ... The first parklets were installed throughout 2010. These five pilot projects were situated in four neighborhoods of San Francisco ... Every year since 2010, more parklets have appeared around the City under the sponsorship of nonprofits, small businesses, neighborhood groups, and others. Each generation of parklets helps us understand how to better increase open space where our neighborhoods need it most."

<http://pavementtoparks.org/parklets/>



Rain Water collection and informational facts



KEY ELEMENTS:

The design was planned with and for the children of the community and Horace Mann Middle School.

Design utilizes the streetscape as a safe, educational space for waiting school children.

FACTS:

Location: San Francisco, CA, U.S.A.

Designer: Exploratorium's Studio for Public Spaces

Cost/Funding: National Science Foundation for STEM Learning

Maintenance: Buena Vista Horace Mann Middle School and the San Francisco Boys and Girls Club

APPLY THIS TO A BUS STOP DESIGN:

CONSIDER A PARKLET DESIGN FOR A BUS STOP:

-if the city desires promotion of non-vehicular transportation

-if space is available to create a complete street

-if funding for an urban educational space is presented - i.e. Ciencia Publica: Agua Parklet: supports informal education in science, technology, engineering, and mathematics (STEM) within the Latino community

-if a local business or restaurant demonstrates interest in pairing with a parklet for additional street presence and event space

*See Transit Guide Chapter 2 for design dimensions, rules and regulations. Refer to your city's existing codes and regulations for adjusting guidelines.

PRECEDENTS

6. THE PORCH AT 30TH STREET STATION

“The Porch, located on the south side of 30th Street Station, is one of Philadelphia's premiere public spaces. The Porch features lunch from rotating food trucks, pop-up performances, lush landscaping, outdoor drinks Wednesday-Friday, and plenty of places to relax.”

<https://www.universitycity.org/the-porch>

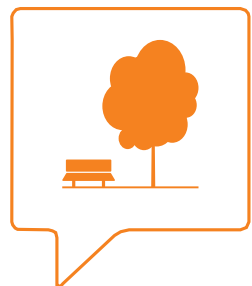

KEY ELEMENTS:

The Porch establishes a multi-functional public space that promotes the arts and entertainment.

The design transformed 33 parking spaces (55'x500') to create an urban center of gathering and events for a transit station in Philadelphia.

FACTS:

Location: Philadelphia, PA, U.S.A.

Designer: University City District (UCD)

Cost/Funding: UCD, PECO, and PennDOT

Maintenance: UCD and Green City Works

APPLY THIS TO A BUS STOP DESIGN:

CONSIDER AN 'URBAN PORCH' FOR A BUS STOP:

-if a large space or vacant lot near a transit line can be turned into a place of gathering to foster neighborhood interaction

-if multiple restaurants and businesses desire a greater street front presence

*See Transit Guide Chapter 2 for design dimensions, rules and regulations. Refer to your city's existing codes and regulations for adjusting guidelines.

PRECEDENTS

7. ESCALE NUMERIQUE - PARIS WI-FI STATIONS

“French designer Mathieu Lehanneur has created a series of Wi-Fi stations in Paris where people can sit down to use their laptops or access local information via a large screen. Named Escale Numérique, which translates as Digital Break, the proposal won a competition to design street furniture that links with the underground fibre-optic network so residents and visitors without mobile internet access can connect on the move.”

<http://www.feeldesain.com/category/event-2/category/architecture/page/40>



KEY ELEMENTS:

The design of the wi-fi station beautifully calls attention to the service and information being provided to the city.

The design rethinks urban ‘offices’ by providing a space to work while waiting.

FACTS:

Location: Paris, France.

Designer: Mathieu Lehanneur

Cost/Funding: Mathieu Lehanneur and JCDecaux

Maintenance: The City of Paris

APPLY THIS TO A BUS STOP DESIGN:

CONSIDER A ‘WI-FI’ STATION FOR A BUS STOP:

-if the site space is limited but there is funding for an additional amenity to provide service to a waiting passenger

-if the city or an organization wants to connect transit and technology by improving the resources and amenities of their public spaces

*See Transit Guide Chapter 2 for design dimensions, rules and regulations. Refer to your city’s existing codes and regulations for adjusting guidelines.

PRECEDENTS

8. JAMAICA PLAIN AND MISSION HILL

“The City of Boston is interested in extending the sidewalk to accommodate patio seating and attracting more pedestrians to the commercial areas. Jamaica Plain and Mission Hill are two separate parklets as part of a pilot program to observe the pros and cons of replacing parking spots, in an already car congested community, to pockets of social ‘hotspots’. These parklets encourage interaction and promote commuter foot traffic”(Boston Magazine). The Jamaica Plain and Mission Hill, two separate parklets, were funded by the Boston Transportation Department in order to bring more activity to the commercial districts that lack street presence and space for pedestrian gathering. Both Parklets support the local businesses and restaurants in their respective neighborhoods.



Jamaica Plain on Centre St. is next to Sonia’s Bridal and Quinceanera and Tacos El Charro

Mission Hill on Tremont St. is across from Mike’s Donuts and Lily’s Pasta Express



KEY ELEMENTS:

The parklets bring the community together through rethinking the street scape as a place of gathering.

The partnerships with local businesses provide local economic generation as well as a system for maintenance and upkeep.

FACTS:

Location: Boston, MA, U.S.A.

Designer: Kyle Zick Landscape Architecture

Cost/Funding: \$15,000 paid by the Boston Transportation Dept.

Maintenance: local businesses maintain plants and regular upkeep

APPLY THIS TO A BUS STOP DESIGN:

CONSIDER A PARKLET DESIGN FOR A BUS STOP:

- if the city desires promotion of non-vehicular transportation
- if space is available to create a complete street
- if a local business or restaurant demonstrates interest in pairing with a parklet for additional street presence and event space

*See Transit Guide Chapter 2 for design dimensions, rules and regulations. Refer to your city’s existing codes and regulations for adjusting guidelines.

*More information: <http://www.bostonmagazine.com/news/2013/09/12/boston-parklets-mission-hill-jamaica-plain/>

PRECEDENTS

9. TERRITORI24 MALGRAT DE MAR STREETSCAPE

Territori24 improved a street scape through neighborhood design participation. “Removing the limits between pedestrian and vehicle areas. The urban elements, street sign graphics, arrangement of railings, benches and trees lends order to vehicle parking and helps to create small meeting and rest spaces along the street. Segre Street, with its more than 20% gradient, serves as a nexus between the Castell neighborhood and Francesc Macià Park. The signage used throughout the space blurs the boundaries between vehicles and people, the arrangement of the trees obliges drivers to slow down, and the low bollards order the parking. All of this is aimed at turning the street into a meeting point for local residents.”

<http://territori24.com/?projects=segre-street>



KEY ELEMENTS:

Community input on the design determined the arrangement of the streetscape elements.

The design revitalizes the neighborhood and preserves the existing topography.

FACTS:

Location: Malgrat de Mar, Spain

Designer: Territori24

Cost/Funding: Malgrat de Mar Town Council - €300,000

Maintenance: Malgrat de Mar Town Council

APPLY THIS TO A BUS STOP DESIGN:

CONSIDER A ‘STREET GRAPHIC’ DESIGN FOR A BUS STOP:

-if there is an expressed interest in a complete street - i.e. reprogramming the street to include multiple forms of transportation while emphasizing the pedestrian

-if the existing street needs improvement and opportunity is found through pairing with a transit agency and neighborhood organization to create a unique streetscape

-if the neighborhood wants to participate in the rebranding of their street-scape design

*See Transit Guide Chapter 2 for design dimensions, rules and regulations. Refer to your city’s existing codes and regulations for adjusting guidelines.

PRECEDENTS

10. PHONE BOOTH-LIBRARY NYC

“John Locke thought people should read more so he built up a set of shelves with books in them and installed them in some pay phone booths to encourage people to utilize them.” This was intended as a means of spreading knowledge across the city through an already existing network of structures.

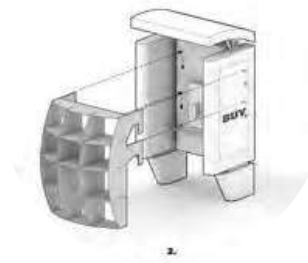

KEY ELEMENTS:

Design provides an alternate use of an underutilized element of the city while promoting reading, learning, and sharing.

Design utilizes existing structures to creatively engage the community.

John Locke designed the booth to be easily fabricated and installed while maintaining operation and signage requirements.

FACTS:

Location: New York City, NY, U.S.A.

Designer: John Locke

Cost/Funding: books donated, materials milled by Kontraptionist

Maintenance: John Locke

APPLY THIS TO A BUS STOP DESIGN:

CONSIDER A MINI-LIBRARY FOR A BUS STOP:

- if an existing structure has to remain
- if there is a limited site footprint for design (see Ch. 2 for 'small site' dimensions)
- if funding is presented for a small project to better connect the city with transportation

*See Transit Guide Chapter 2 for design dimensions, rules and regulations. Refer to your city's existing codes and regulations for adjusting guidelines.

*More info: <http://gracefulspoon.com/blog/2011/07/06/dub-002/>

PRECEDENTS : VISUALIZED IN SACRAMENTO

1.1. TACTICAL ACTION 'STREET STENCILS'

The Maple School Site in Sacramento, California suffers from a lack of street presence and lack of proximity to mass transit stops. Though it is part of a larger community and business district along Franklin Blvd., the center is not easily recognizable from the street as a neighborhood center. Street stencils would visually identify and connect important community nodes, providing an opportunity for district branding along the Franklin Blvd. corridor. The images below represent precedents that successfully utilize street stenciling as a form of branding for the identity of the city.

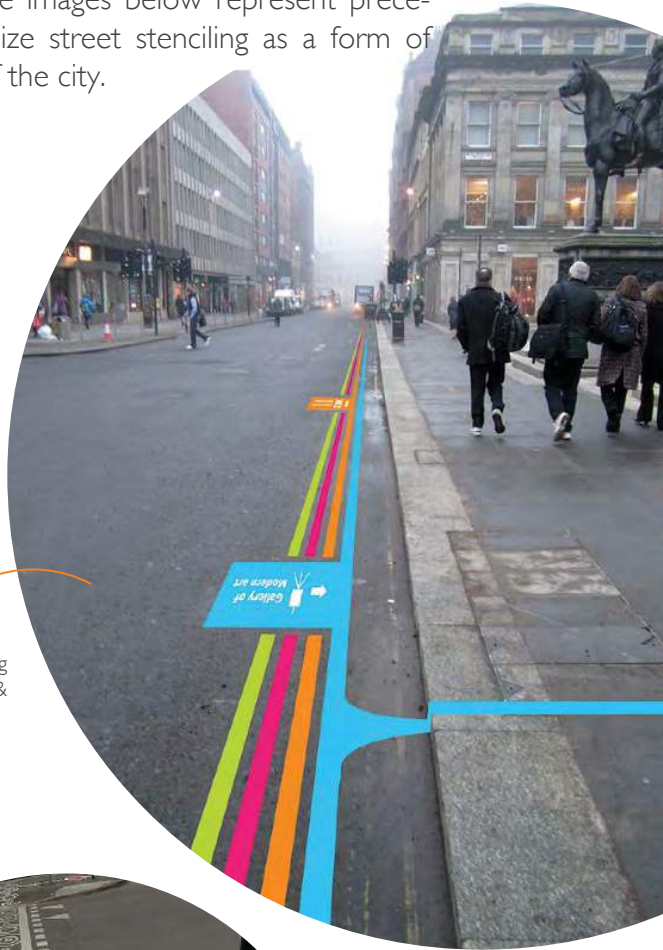

The cycle path - Andrew Lang Graphic Design, Typography & Art direction



KEY ELEMENTS:

Street stenciling would locate the Maple School site as central to the neighborhood network.

Visual branding through use of bright graphics provides the wayfinding necessary to develop an identity for the strongest aspects of the community.

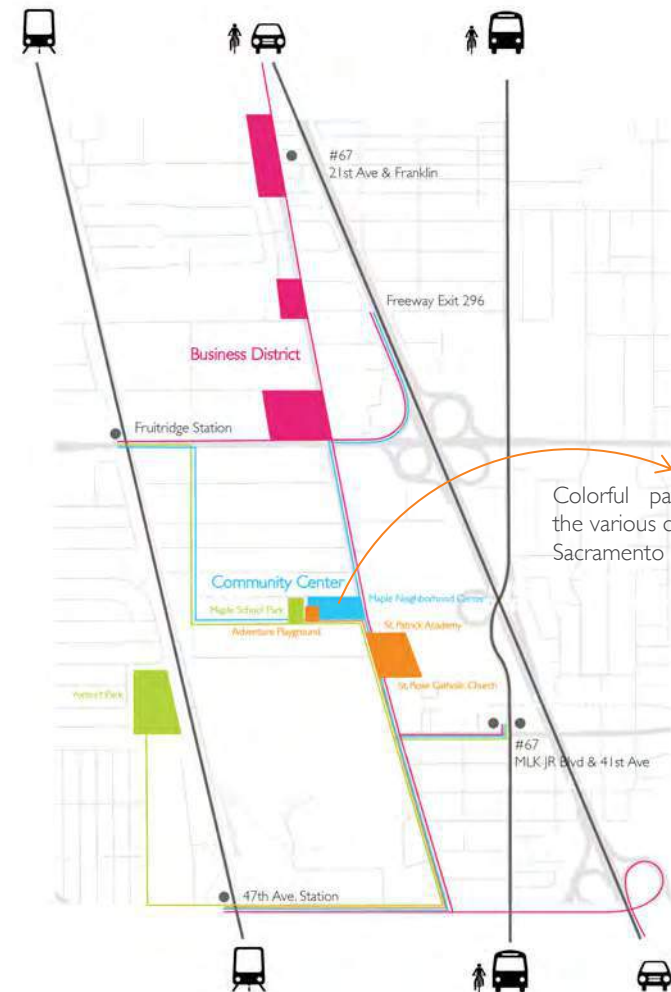

Colorful pathways connecting the various districts of the South Sacramento neighborhoods.

PRECEDENTS : VISUALIZED IN SACRAMENTO

12. TACTICAL ACTION 'WALKING PATHS'

The Franklin Blvd. corridor poses many challenges for pedestrians and mass transit riders. The walks from transit stops to key areas of interest are long and circuitous, the sidewalks are narrow and abut the street, and there is little shade along pedestrian routes. These factors make pedestrian travel in this area unpleasant. Providing Walking stops that could also double as shade would provide moments of respite and liven up the streetscape. The project below was designed by KLAR, Future Experience, U-Turn, and White Water Adventure Park under the leadership of Julien De Smedt as an element of Copenhagen's new public waterfront. The elements of this design serve as inspiration for potential 'Walking Paths' along Sacramento's unwalkable streets.



Copenhagen's Kalvebod Brygge incorporates this linear playground that could be easily utilized in a streetscape.

KEY ELEMENTS:

A walking path would identify resting points or landmarks along an existing or proposed transit line.

Design creates areas of shelter from the elements and opportunity for additional amenities along Franklin Blvd.

BEST DESIGN STRATEGIES: SACRAMENTO, CA

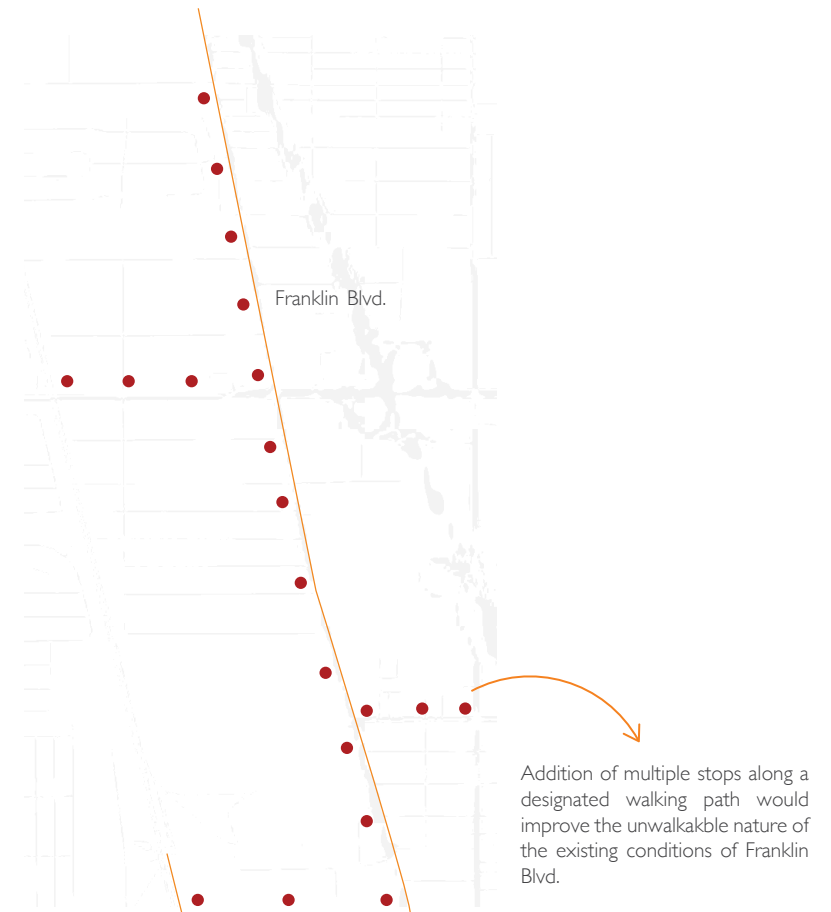

PRECEDENTS : VISUALIZED IN SACRAMENTO

13. TACTICAL ACTION 'MURAL CROSSING'

The images below show examples of street murals as placemaking.

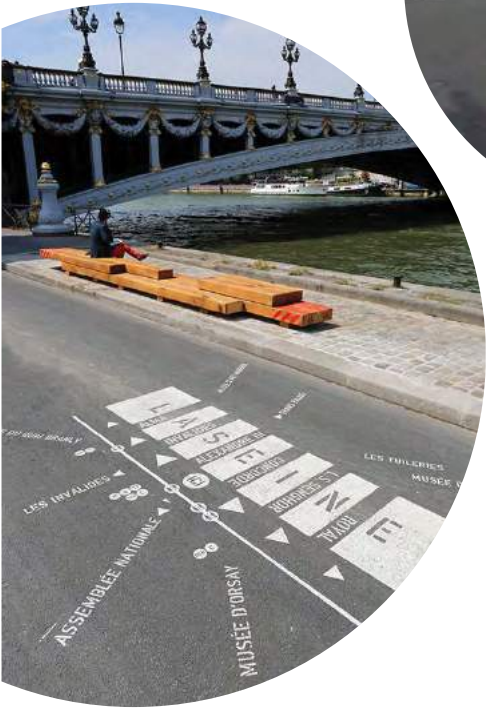

KEY ELEMENTS:

The entrance to the Maple Neighborhood Center is mid-block on a side street, and the building itself lacks street presence. Its closest Neighbor, St. Patrick's Church and Academy, is separated by a 5 lane street. A crosswalk at this intersection would connect these two centers, and slow traffic. A street mural crossing would provide an opportunity for storytelling; to call attention to the community's needs for safe crossing and express what could be if a cross walk was installed at the intersection.

BEST DESIGN STRATEGIES: SACRAMENTO, CA



*How can
the community
be*

empowered

*by the
design
process*

CHAPTER 4: COMMUNITY ENGAGEMENT

Community engagement is an essential step at the beginning of a process aiming to serve and empower a community. When executed thoughtfully, the process can result in a community with a greater sense of shared goals, strategies for overcoming challenges, and neighborhood identity. It is not uncommon for a dialogue that is begun within the context of a design charrette to continue among attendees, resulting in self-led community efforts outside of the original scope. Ideally, a community is better for the engagement process even before anything is ever built. When the focus of the community engagement is built, the resulting structure/space is far more likely to be protected, maintained, and utilized when the community feels true co-authorship over the project. However, too often communities are engaged only for engagement's sake and feel disconnected from both the process and product, with little incentive to contribute to a project's success.

The engagement activities illustrated here represent strategies employed by the Center for Public Interest Design that we have found to be successful approaches. Supplemented with examples from a range of projects, this section will include engagement activities conducted with communities in Sacramento. The engagement tools and activities that will be discussed are categorized here as follows:

- >Design Charrette
- >Community Created Infographics
- >Directed Feedback Activities
- >Unstructured Activities
- >Online engagement

While scalable to allow for variations in time, money, and human power available on a given effort, a combination of multiple approaches will likely be required for a meaningful outcome.

4.1 DESIGN CHARRETTE

A design charrette is a focused period of design or idea generation with a range of project stakeholders at the beginning of a project to determine a project's design drivers and a shared path forward. Charrettes may last for a few hours to several days. We found that an ideal amount of time for a charrette at the beginning of a project to be between 2 and 4 hours. This is enough time to have meaningful interactions without losing steam.

In the fall of 2016 the CPID hosted a city-wide charrette that brought together architects, housing advocates, and homeless individuals to explore potential solutions to Portland's housing crisis. Over 100 people worked together on a vision for creating tiny houses called pods that form a village in their aggregation. 14 teams were formed as a result that each delivered a set of designs and a built prototype pod that has led to the creation of Portland's first city-sponsored village. With city officials invited to the event, the process itself led to the City's commitment to fund the initiative and find homes for the pods if the project moved forward. It certainly did and just a few months later community charrettes were held in the neighborhood of the proposed village site, giving potential neighbors a chance to help create the village's relationship with the neighborhood while learning about the issues and realities of homelessness. When the neighborhood gathered to vote on whether or not to allow the village into their community, it was the participants in the charrette that became the most vocal advocates and, defying prevailing expectations, the neighborhood voted overwhelmingly to welcome the village into their community.

In Sacramento, the CPID has held design charrettes with La Familia and other stakeholders involved in the Maple Center site, which has informed a series of visions, planning, and tactical proposals for the site.

Below is a typical charrette agenda, and is the one that was used for the POD Initiative in Portland described above.

Agenda

Saturday, October 1, 2016 at Mercy Corps

11:30am – 12:30pm- Participants encouraged to visit site that is topic of charrette

12:30pm - 1pm – Snacks + Check-in

Charrette

intro Speakers

1:00 – 1:05 pm – Greetings & Overview of Project and Day's Goals

1:05pm – 1:15pm - Speaker 1 – Providing overview/context for homelessness issues

1:15 – 1:20pm – Speaker 2 – How design can play a role in complex issue

1:20 – 1:35pm – Speaker 3 – Homeless Portlander on issues based on lived experience

1:35 – 1:45pm – Detail the goals for the afternoon

Break into Work Groups (Tables of approx. 6-8, mix of participants)

1:45– 1:55 pm: Table Introductions and Goals led by pre-assigned table leaders

1:55 – 2:15pm: Group Strategies – Define areas to pursue

2:15-2:30pm – Initial Design

2:30-2:40pm - Group Check-in- Sharing Questions and Big Ideas (ALL)

2:40– 3:30pm: Group Design

3:30 – 3:55pm: Wrap-up + Discussion (ALL), groups present their ideas

3:55-4pm: Organizers discuss next steps

4pm: Mayor Hales closing remarks

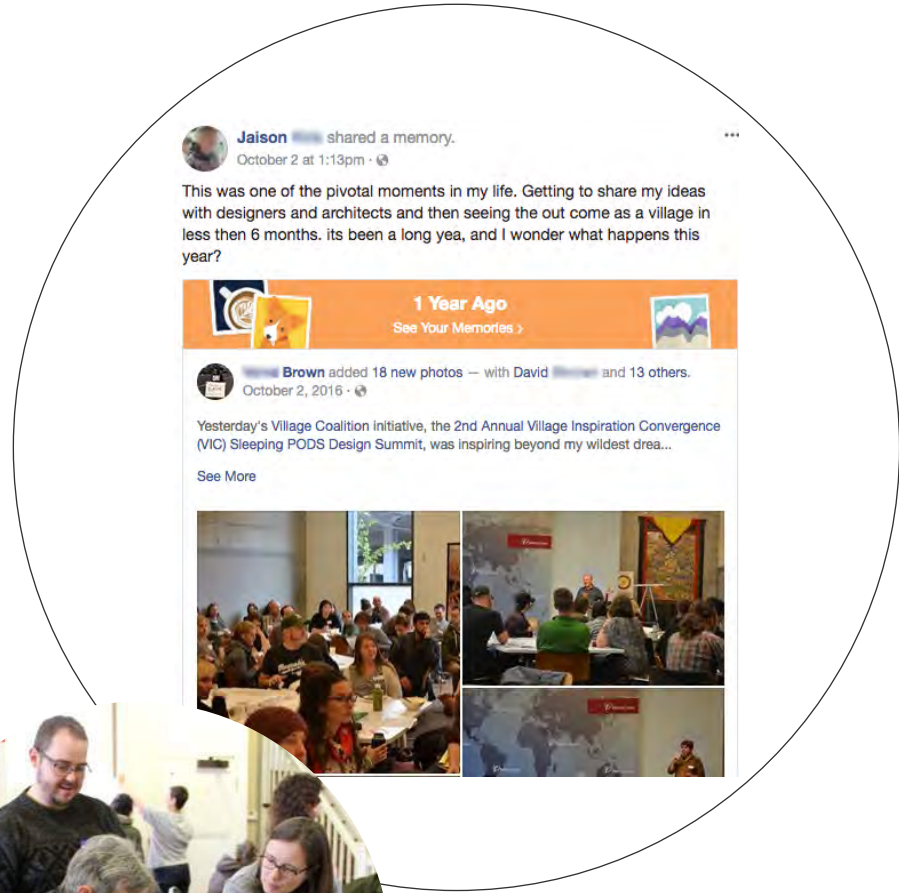

4.2 COMMUNITY CREATED INFOGRAPHICS

When considered methods of engagement, it is important to consider a community's past experiences with other groups or agencies with a similar focus to your own. Often the most marginalized groups feel over studied and underserved- with information collected in their community disappearing with the researcher in what may appear to be a secretive or mysterious process. One of the best ways to prevent this perception is to allow the information to be visible as it is being collected for all to see. A more transparent process can also create a dialogue among neighbors if they find that there are shared ideas and goals, or equally about surprising differences of opinion that may prevent community progress.

The CPID created a useful tool for the Right 2 Root campaign, an initiative aimed at combating the displacement of the African American community from the central city of a quickly gentrifying Portland. The tool offered participants in community workshops and charrettes the opportunity to contribute to voicing their opinion on a variety of issues through coded variables of size, color, and written text- but, more importantly, the tool created an infographic for the community to see, learn from, and respond to. The process was transparent and the data collected remained within the community, rather than collected on a clipboard never to be seen again. The community embraced the aesthetics of the tool itself and it continues to provide the backdrop at Right 2 Root gatherings.

In Del Paso Heights, the CPID was tasked with generating design possibilities for a neighborhood park that would soon be home to competitive baseball fields for teams throughout the region. As a burgeoning sports center, the CPID asked local residents what sports they would be most interested in playing in the park. The responses were documented by adding a helium-filled balloon to a growing string for each answer, with a different color representing a specific option. The result was a fun, and highly visible, graph of sorts that attracted interest for further feedback and discussion.

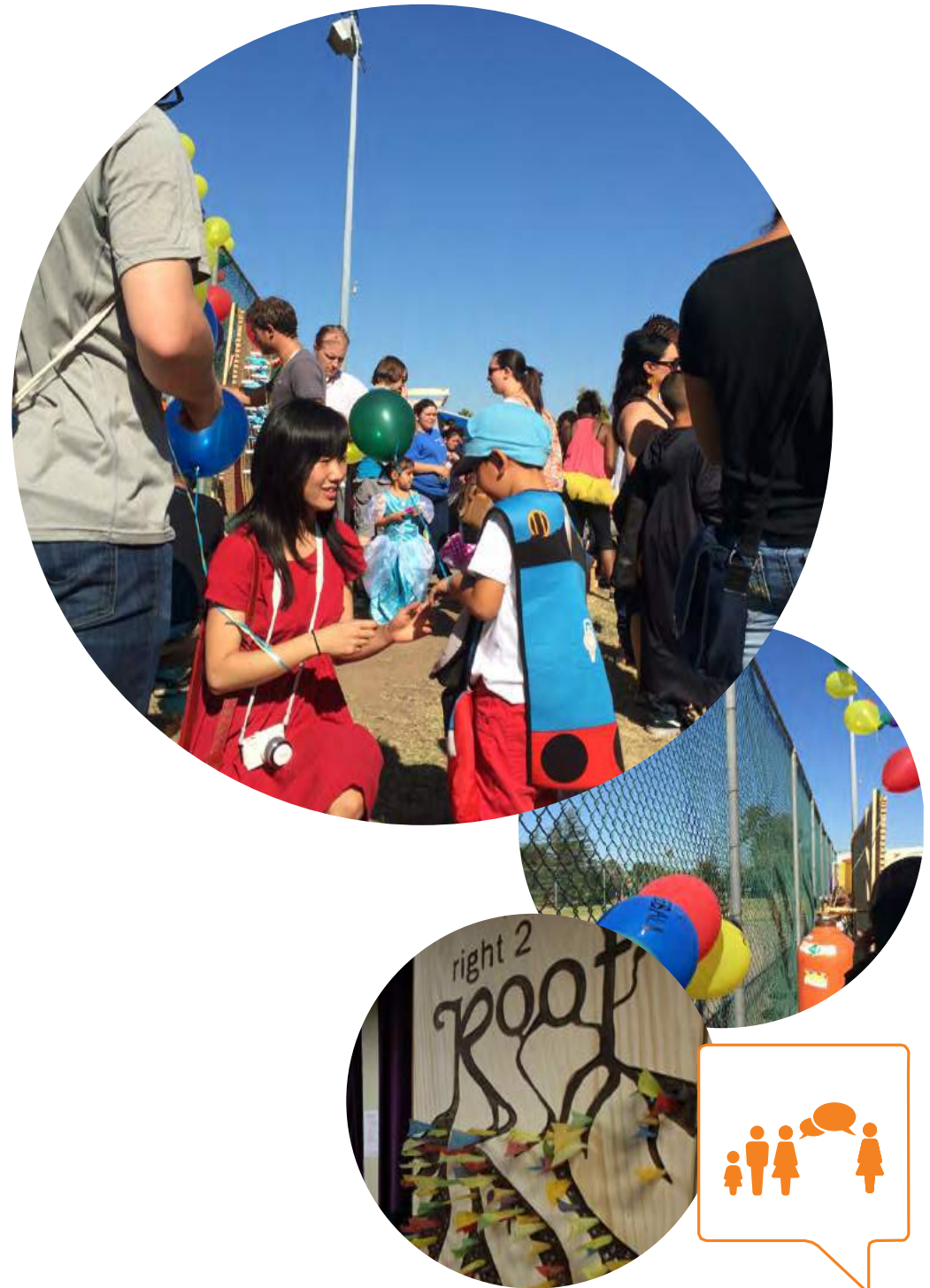

4.3 DIRECTED FEEDBACK ACTIVITIES

A project often demands specific feedback and data collection that is difficult to collect in a charrette or with an infographic tool. Primary considerations when considering what feedback is needed and how to gather the information is to ask: How long will I need to spend with each person giving feedback? What will incentivize an individual to give feedback? How can this feedback be collected in a way that is transparent for both what is being collected and what will be done with the information? Does this feedback activity need a facilitator to be present?



4.4 LIGHTLY STRUCTURED ACTIVITIES

Being focused with questions and activities to garner specific information for a project is crucial for efficiently using time and resources for all involved. However, only utilizing highly structured activities risks missing out on important information about a community or place that can have significant impact on a project. Creating lightly structured activities often allows engagement with residents you might not otherwise be able to reach in a format that allows for community members to define what is important and what should be discussed. This can be particularly helpful at the beginning of a project for identifying challenges and opportunities in an area and as a precursor to asset-mapping and other more focused activities.

Two activities led by the CPID at Del Paso Heights' Harvest Festival in 2015 speak to this approach. While several activities aimed at gathering specific information about community transportation needs and desires for a neighborhood park, there was an activity for mask making with children (it was a Halloween-themed event) and another where attendees could write on blue or white cards and place them in a "wishing wall" representing hopes for the community (white) and challenges that they see (blue). In both cases, the activities brought children and their parents to the activity station, but the conversations had while completing the activity were invaluable for understanding the community from residents' perspectives and establishing relationships.

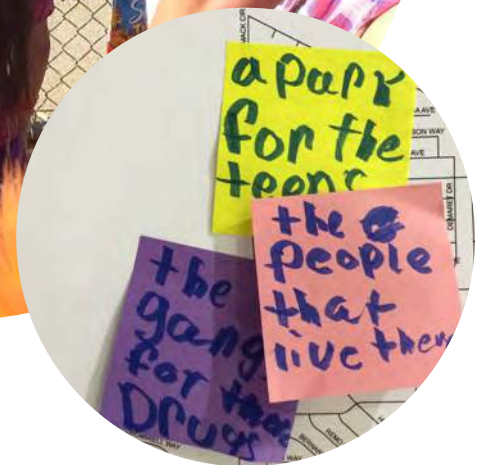

4.5 ONLINE ENGAGEMENT

While it is, of course, preferable to meet with project stakeholders in person, this is not always possible or realistic. Even making a concerted effort to meet people where they already gather rather than asking them to come to you can leave out those working multiple jobs, caring for a family member or children on their own, struggling with reliable or affordable transportation, etc. Often, those members of the community that may be most affected by a project and may have the most to contribute are the ones left out of the conversation because of these and other circumstances. In response to this concern, the CPID partnered with the renowned Madrid-based architecture and urban design firm, *ecosistema urbano* [sic], to develop a web-based tool for community engagement in underserved areas. The With Project grows out of the innovative work that *ecosistema urbano* has done in creating participatory design processes around the world and aims to provide opportunities for ongoing feedback about community desires, challenges, and opportunities. The tool was created with SACOG and will have accumulating, geo-referenced, documentation to better advocate for communities.

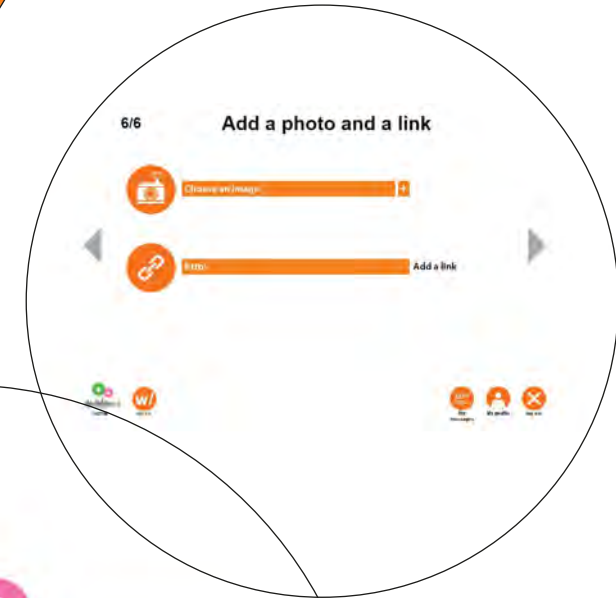
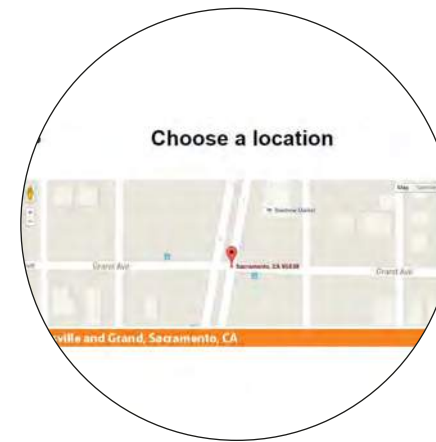

*What might
an*

***enhanced
bus stop***

*look
like*

CHAPTER 5: ENVISIONING (NEW) BUS STOPS

The design of new bus stops for a community provide the most opportunities in terms of fulfilling specific programmatic and functional needs. The process, from start to finish, facilitates a collaborative effort with the end result being a design that considers the needs of all stakeholders. With new construction, the creative solutions are free from the restrictions of an existing bus shelter or amenity, and therefore re-envision the programmatic possibilities. The following pages explore the design potential of bus stops in the creation of more sustainable and healthy amenities for members of the community.

CHAPTER 5:

The following design proposals were created by the CPID to capture a range of ideas that have emerged toward better bus stop designs, followed by three built precedents of enhanced bus stops. The designs address needs by leveraging community strengths identified by organizations and the members of those communities. Each proposal addresses the practical needs of the operator and neighborhood by incorporating design elements that support safety, accessibility, and visibility through placemaking strategies. Placemaking encourages investment in the infrastructure of the stops to make them more than a stop along the way. Each proposal incorporates an element of placemaking that engages the community in the design process. These stops are designed for a designated open space and do not incorporate existing shelters or benches. (See Chapter 6 for existing bus stop interventions). They expand or contract based on the given footprint for design.

- 5.1 - Oasis
- 5.2 - Link
- 5.3 - Rhythm
- 5.4 - Diffuse





5.1 OASIS BUS STOP

“The neighborhood community is the expert on what types of programs would best serve the residents and the type of design that will best reflect the neighborhood. The intent is that the community drives the development of the Oasis Stops through a series of workshops with local residents. The workshops offer the residents a voice in choosing the program of each Oasis Stop as well as the physical aesthetics of each given Oasis Stop. In addition these workshops offer potential funding and service partners an opportunity to interact with the people that they are hoping to serve.”

-Nicole De Jong

Nicole De Jong
Center for Public Interest Design



micro-retail space



shelter and hydration station for waiting passengers



Nicole De Jong - design proposal

DESIGN

KEY ELEMENTS

Incorporating people spaces, green spaces, and economic spaces into each design increases community investment and longevity of the design.



People Spaces



Green Spaces



Economic Spaces

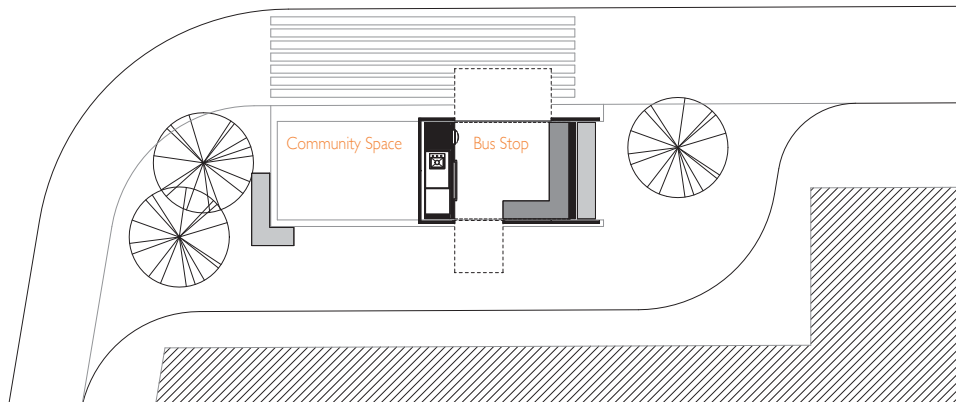

PLAN - 'CLOSED'

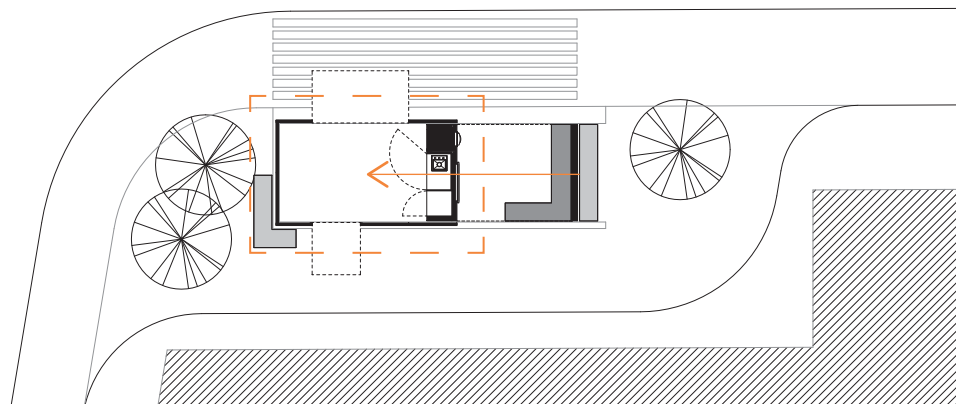

PLAN - 'OPEN'

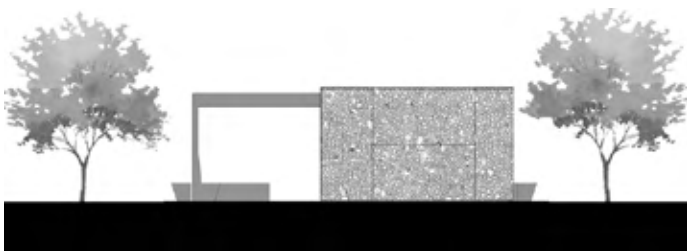

ELEVATION

DESIGN

PLAN - 'CLOSED'

In the 'closed' plan, the Oasis design provides a bus stop area with an outdoor, shaded parklet for the community.

PLAN - 'OPEN'

In the 'open' plan, the Oasis design provides a bus stop area with an additional covered space for the community and its partners. (i.e. to be used for: local business, flu shots, art exhibit, voter registration, etc.)

ELEVATION

Elevation drawing with a sample pattern for exterior. This pattern could be a map, a piece of artwork, etc. and is selected by the community through the design process.

DESIGN

MATERIALS

1. Custom Metal or Wood Screen
2. Wheels
3. Hydration Station
4. Touchscreen Information Board - real time info. updates
5. Bottom Rail
6. Wood or Metal Cladding on Metal Framing
7. Crushed Rock
8. Upper Rail
9. Welded Steel Tube and Metal Framing
10. Service Wall with City Utilities Hook-ups
11. Shade Trees
12. Stone Bench
13. Inset Concrete Pavers
14. Sidewalk

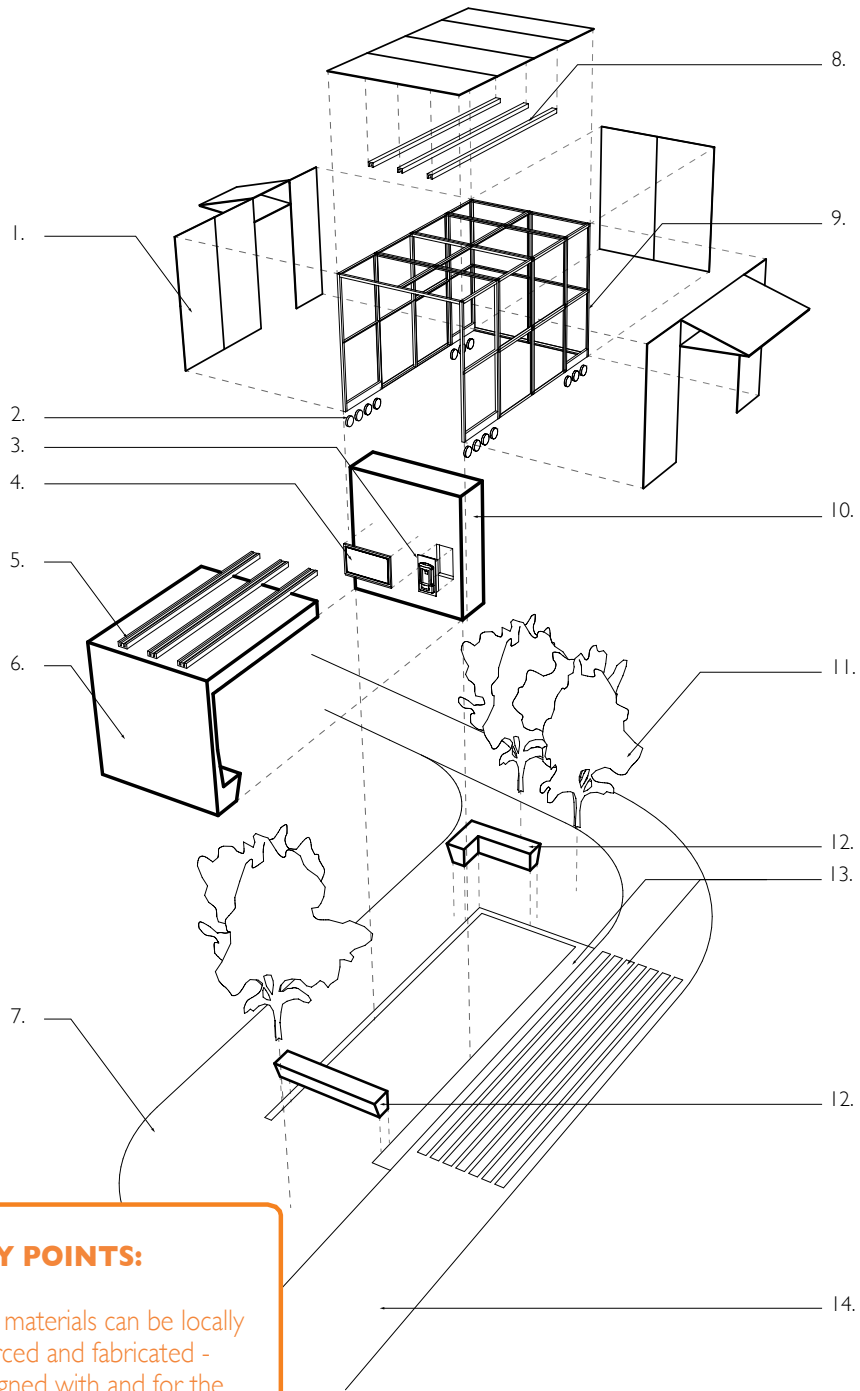

KEY POINTS:

The materials can be locally sourced and fabricated - designed with and for the community members.

DESIGN

DIAGRAM OF TRANSFORMATION

1. The Oasis design seeks to address the issues of existing bus stops through a multipurpose space that transforms based on the needs of the community. The following steps diagram this transformation:

1. Enter the pass code into the digital touch screen. This will unlock the movable screen box (colored in orange) into the 'open' state.

2. Close the awning doors at the front and back of the movable screen box before moving the box itself.

3. Push the movable screen box gently open.

4. Continue pushing the movable screen box open until it reaches the edge of the site bench.

5. Once the movable screen box is fully open, lock it into place before opening the doors.

6. Open one or both doors, depending on the use of the exterior shelter (colored in red).

7. Welcome the community!

1.

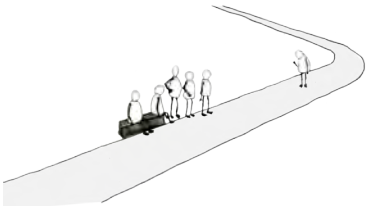

2.

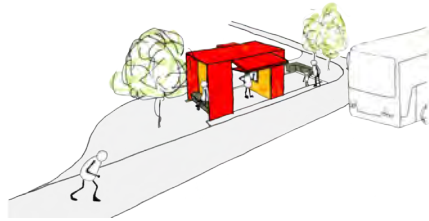

3.

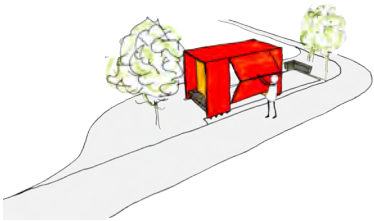

4.

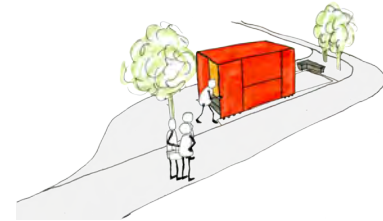

5.

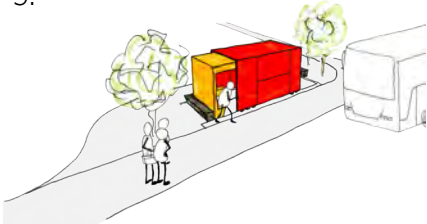

6.

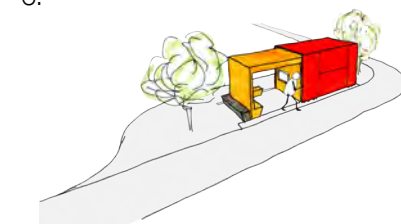

7.

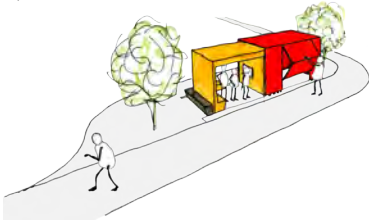

8.

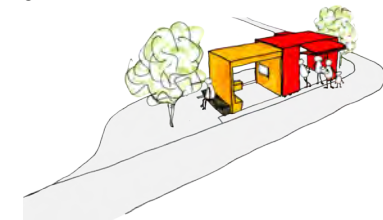



DISCUSS PROGRAM AND NEEDS

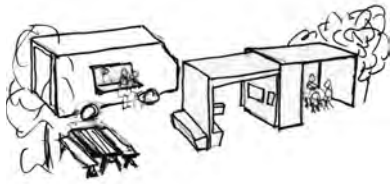

DESIGN CHARRETTE



COMMUNITY ENGAGEMENT

MATERIALS

The process of community engagement depends greatly on the participating stakeholders in the Oasis bus stop. The design proposes a selection of materials and programmatic elements as key to the success of the stop. Below are samples of materials that could be chosen for the screens of the bus stop.

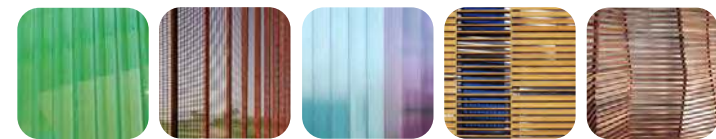



Christopher Kulp - design proposal

5.2 LINK BUS STOP

The Link creates a direct material connection to its urban context by using building materials found in the architecture and infrastructure of the neighborhood. The design and construction process is intended to be a collaborative effort between a local artist, community group and the transit authority. The artist develops a design for the stop shelter using locally sourced materials and the community organization assists with the construction.

Christopher Kulp
Center for Public Interest Design

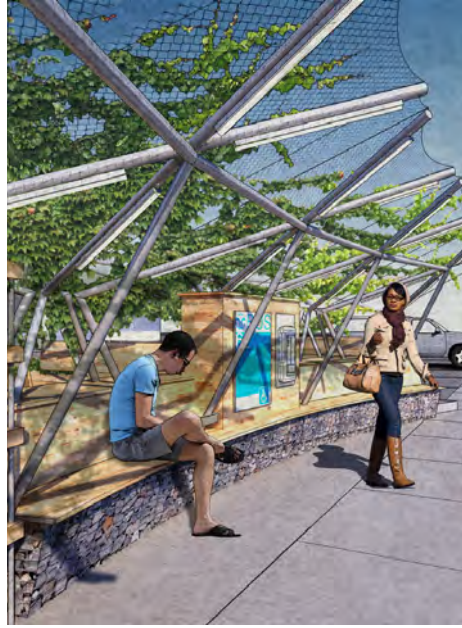

Christopher Kulp - design proposal

DESIGN

KEY ELEMENTS

Incorporating people spaces, green spaces, and economic spaces into each design increases community investment and longevity of the design.



People Spaces



Green Spaces



Economic Spaces

DESIGN

DIFFERENT SCALES OF INTERVENTION

SMALL - At the smallest scale, the Link design provides a safe, shaded space to wait for the bus. This would be ideal for existing conditions that have a limited footprint for design intervention along the street and sidewalk.

MEDIUM - With more space in the 'medium' scale, the stop provides additional seating and program. This scale would benefit a route in need of a significant shaded space along an exposed, unwalkable street.

LARGE - The largest configuration provides a nice gathering space between two or more significant waiting areas. At this scale, the bus stop becomes a community hub to facilitate small events or gathering.

S

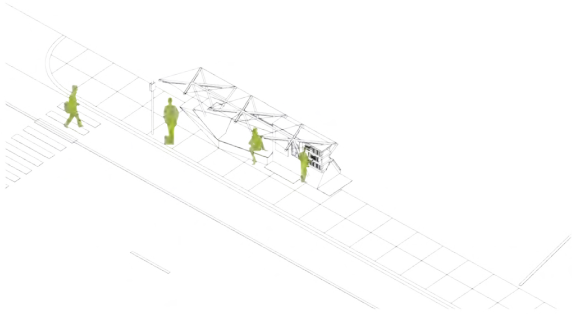

M

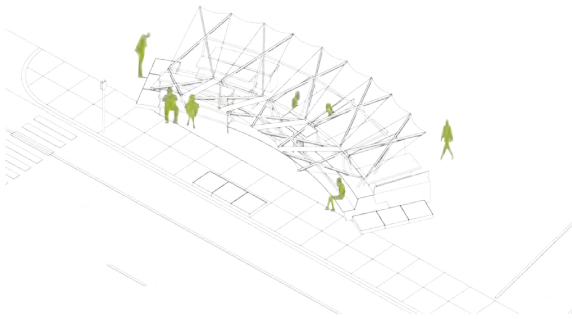

L

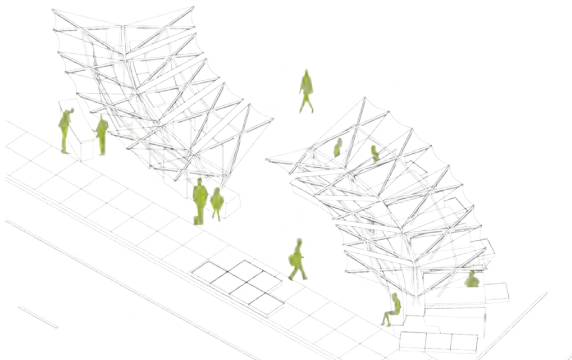

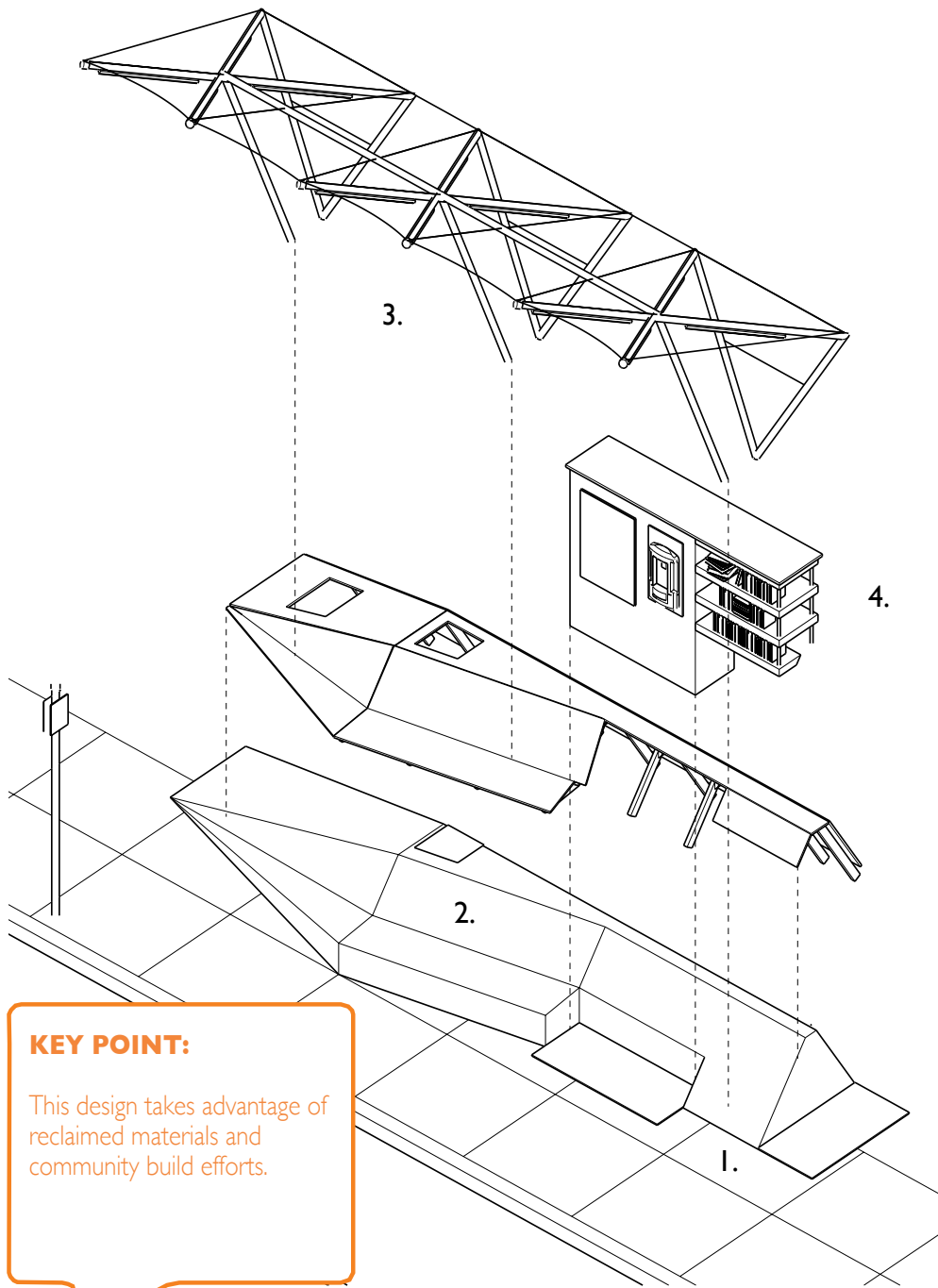

KEY POINT:

This design takes advantage of reclaimed materials and community build efforts.

DESIGN

MATERIALS

1. Gabion Base

Pieces of brick, stone and concrete from abandoned lots in the neighborhood are used in gabions to create a base.

2. Benches, Counters, and Shelves

Reclaimed wood from fences and other various sources is used to create all of the chosen elements as desired by the community.

3. Structure and Shelter

Right-angled, galvanized chainlink fence posts are used to create a structure that is then covered in chainlink fencing and climbing vines to create shade and shelter.

4. Amenities

Amenities* include: hydration station
 rotating bench/counter tops
 schedules

*at the larger scale, the stop will include:
 table seating
 coffee bar or cafe
 simple retail space

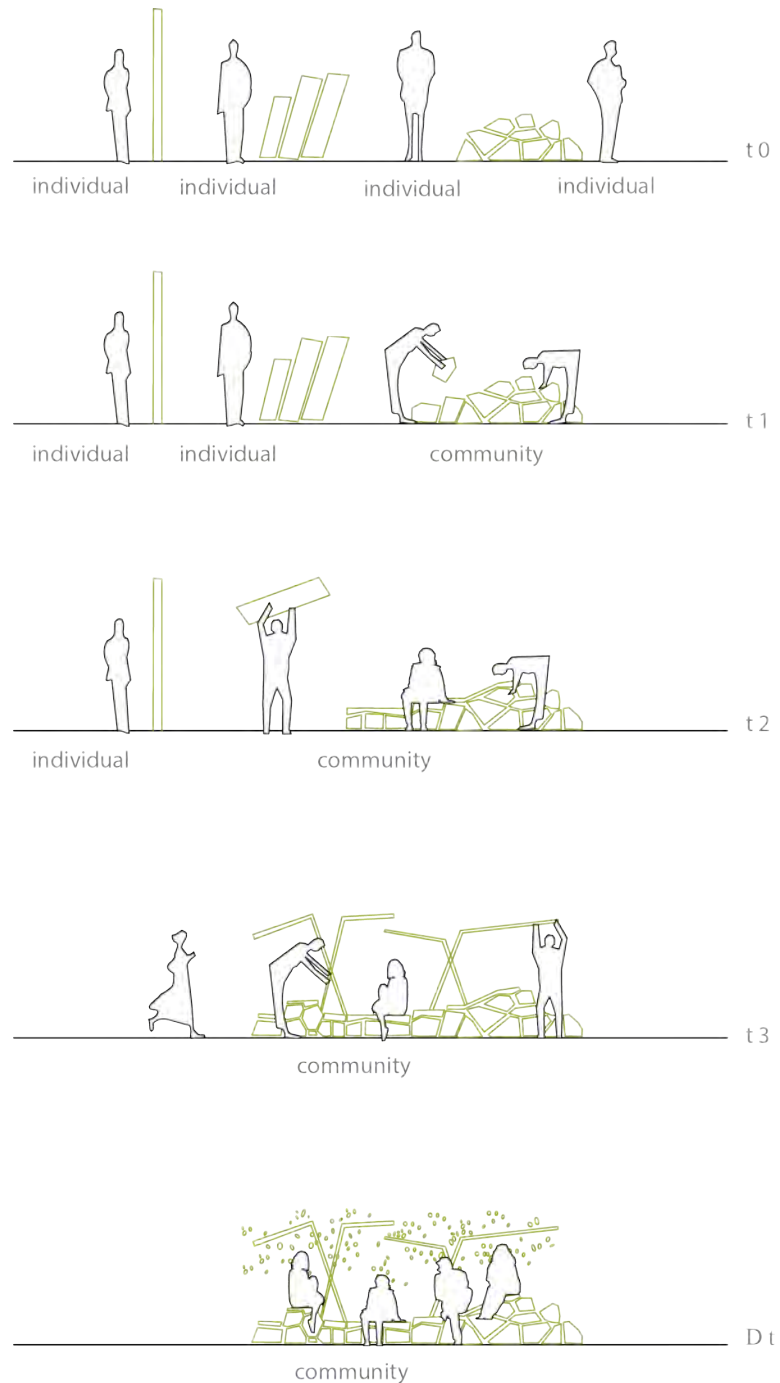

DESIGN

DIAGRAM OF COMMUNITY PARTICIPATION

The Link design emphasizes a community build effort. Through collaboration, a sense of pride develops in placemaking. The creation of this bus stop requires multiple organizations to come together to fund, build, and maintain a space in a community that will ultimately create a safe, healthy place to live.



Laura Beltrami - design proposal

5.3 RHYTHM BUS STOP

The Rhythm stop proposes a modular, additive system that can adapt to variations in site size and project budget. Tube steel is used to create a ribbon of color providing structural support for the program elements while visually connecting them in a rhythmic manner. Amenities can be customized according to the needs of the community. The design incorporates photovoltaic panels to provide lighting for visibility and security and the materials used are easy to maintain and replace.

Student: Laura Beltrami
Center for Public Interest Design



Laura Beltrami - design proposal

DESIGN

KEY ELEMENTS

Incorporating people spaces, green spaces, and economic spaces into each design increases community investment and longevity of the design.



People Spaces



Green Spaces



Economic Spaces



DESIGN

DIFFERENT SCALES OF INTERVENTION

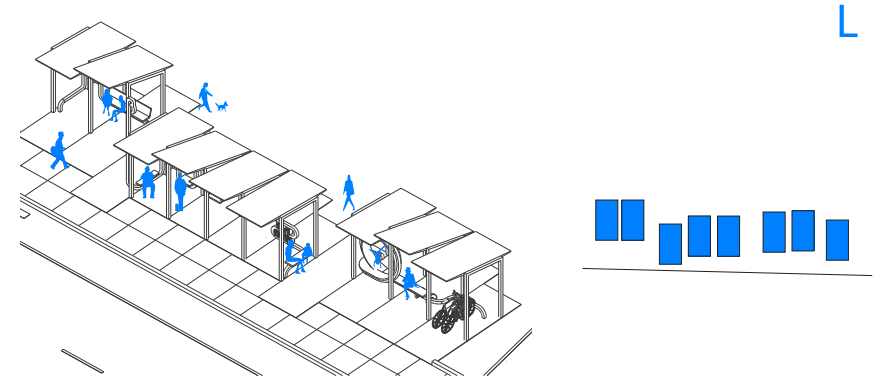
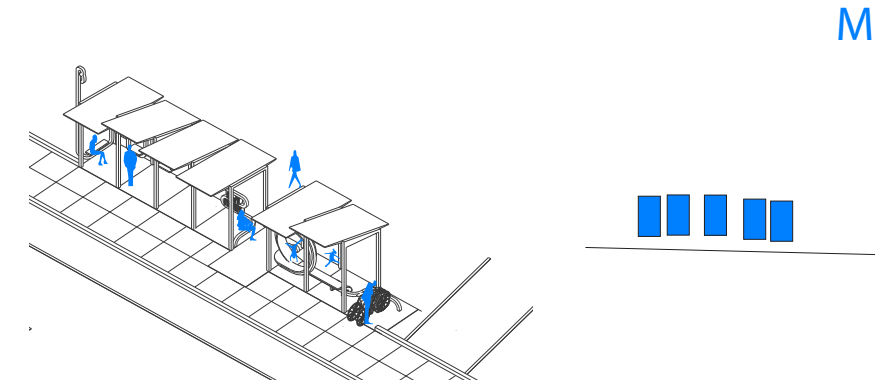
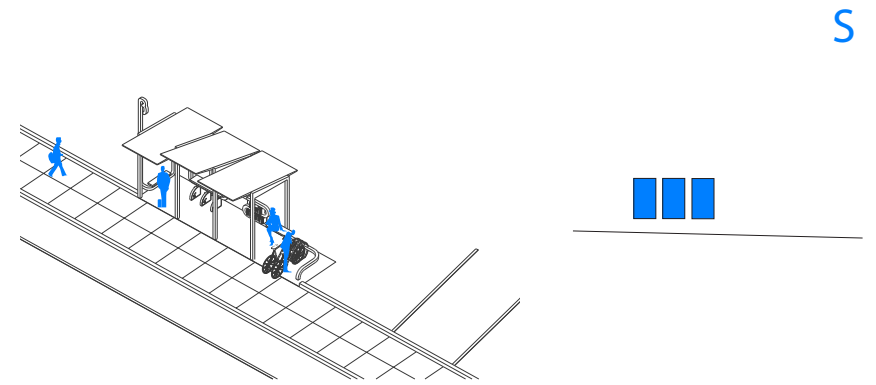

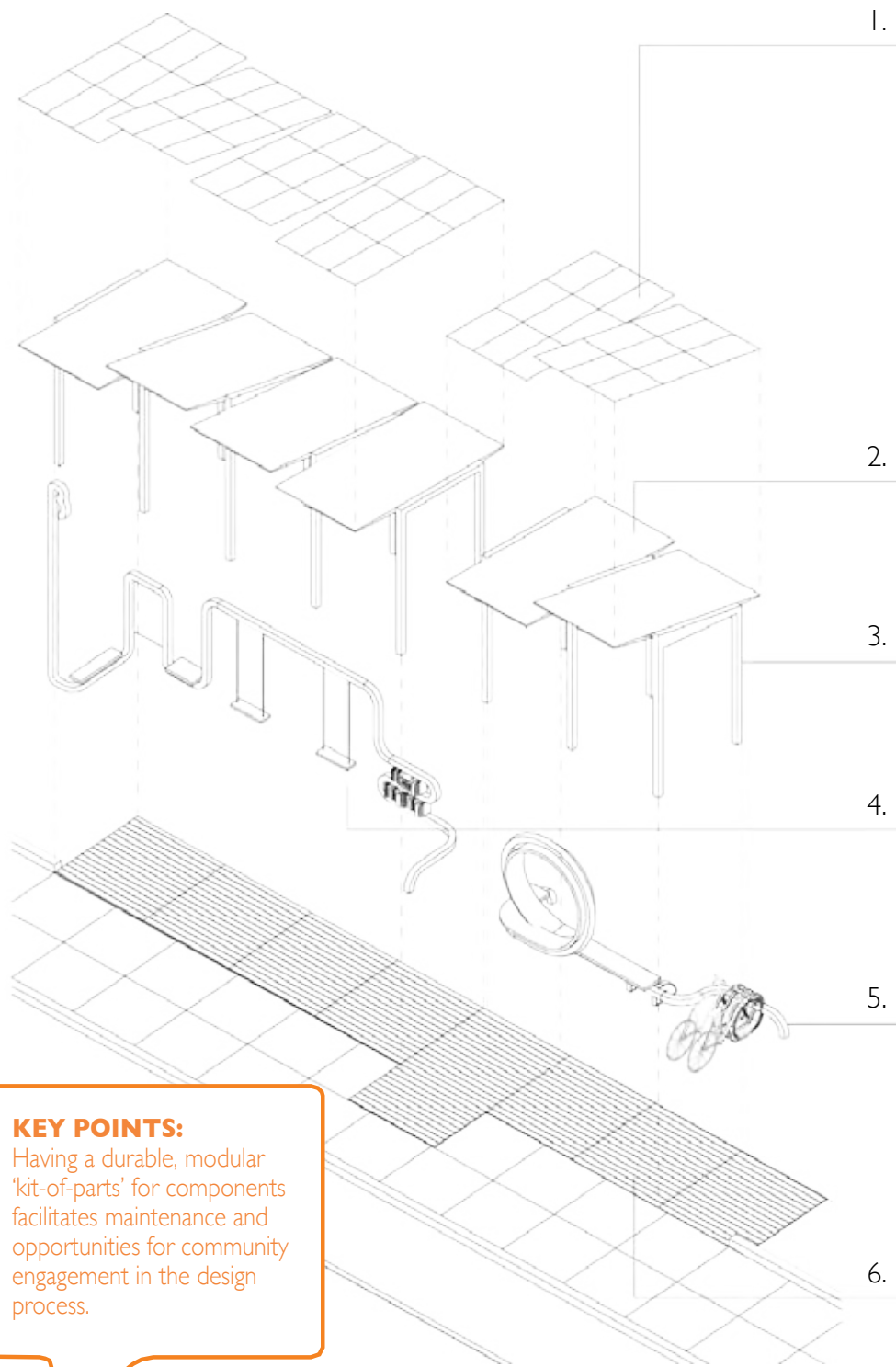

KEY POINTS:

Having a durable, modular 'kit-of-parts' for components facilitates maintenance and opportunities for community engagement in the design process.

DESIGN

COMPONENT MATERIALS

- 1. Photovoltaic panels
- 2. Steel panels
- 3. Steel structure
- 4. Plug-in furniture
- 5. Steel tube armature
- 6. Wood plank floor

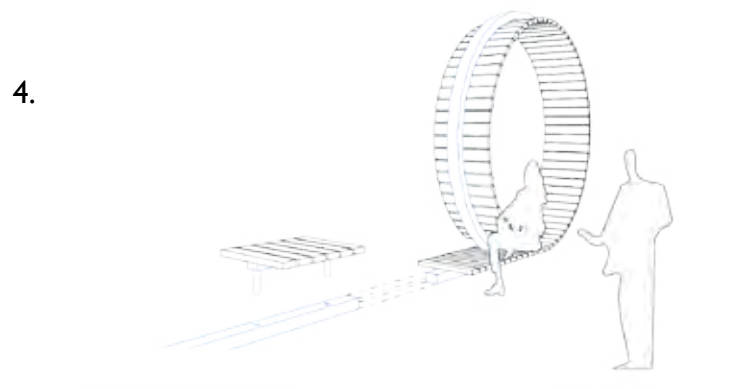
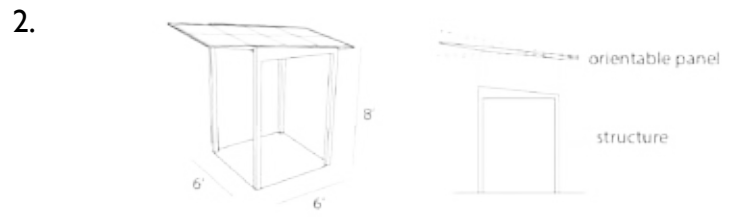
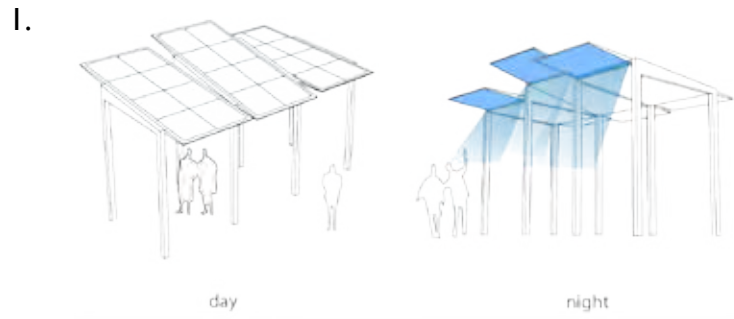

DESIGN

COMPONENTS

1. Photovoltaic panels

The addition of PV panels provide security at night while taking into consideration the energy sustainability of the shelter.

2. Steel panels

The steel panel system facilitates replacement of parts with its modular, orientatble design.

3. Steel structure

The steel tubes provide a simple 'kit-of-parts' design element.

4. 'Plug-in' furniture

The customizable 'plug-in' furniture makes each stop unique.

5. Steel tube armature

The steel tube armature supports the various components such as the cyclette charging station.





Matthew Rusnac - design proposal

5.4 DIFFUSE BUS STOP

The Diffuse bus stop is designed to 'reflect' the community through materiality and programming. Overlapping aluminum channels reflect and refract light to illuminate the space while providing shade from the sun and channeling rainwater to integrated planters. The panel system set between the structure's support columns can be rotated to create different spatial scenarios and amenities for community and rider use.

Matthew Rusnac
Center for Public Interest Design



DESIGN

KEY ELEMENTS

Incorporating people spaces, green spaces, and economic spaces into each design increases community investment and longevity of the design.



People Spaces



Green Spaces



Economic Spaces

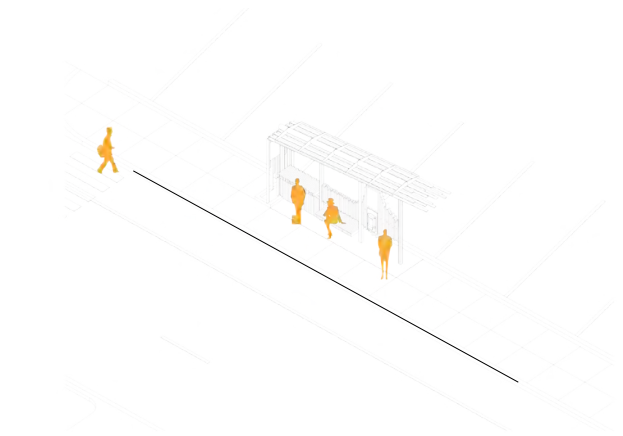

S

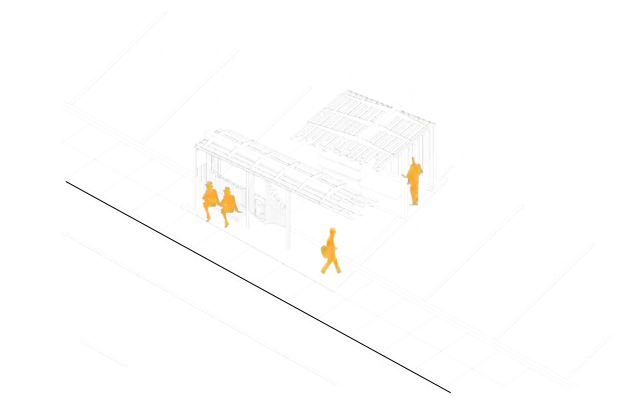

M

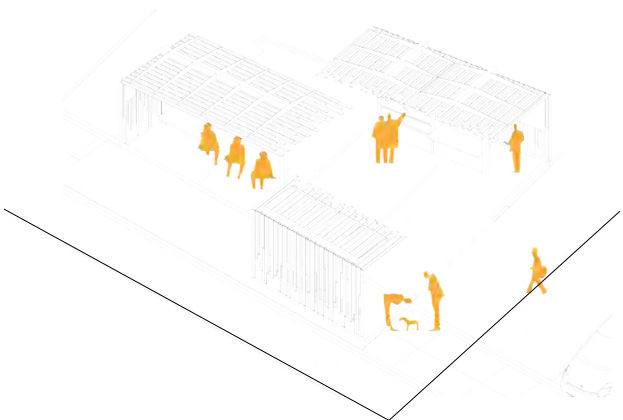
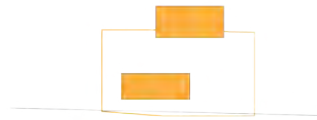

L

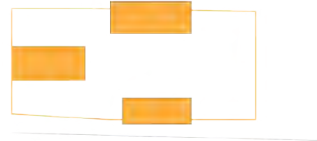

DESIGN

DIFFERENT SCALES OF INTERVENTION

SMALL - The most basic design provides passengers with shelter from the elements, a hydration station, and information within the smallest footprint area stops.

MEDIUM - The 'medium' configuration provides two shelters, one for seating and another for a small programmatic element such as a library or micro-retail.

LARGE - The largest of the shelter configurations creates a mini street-side piazza for the community. It becomes two shelters and a small business stand. This layout provides opportunity for a community 'gate' to a neighborhood through its placemaking and connection to local business.

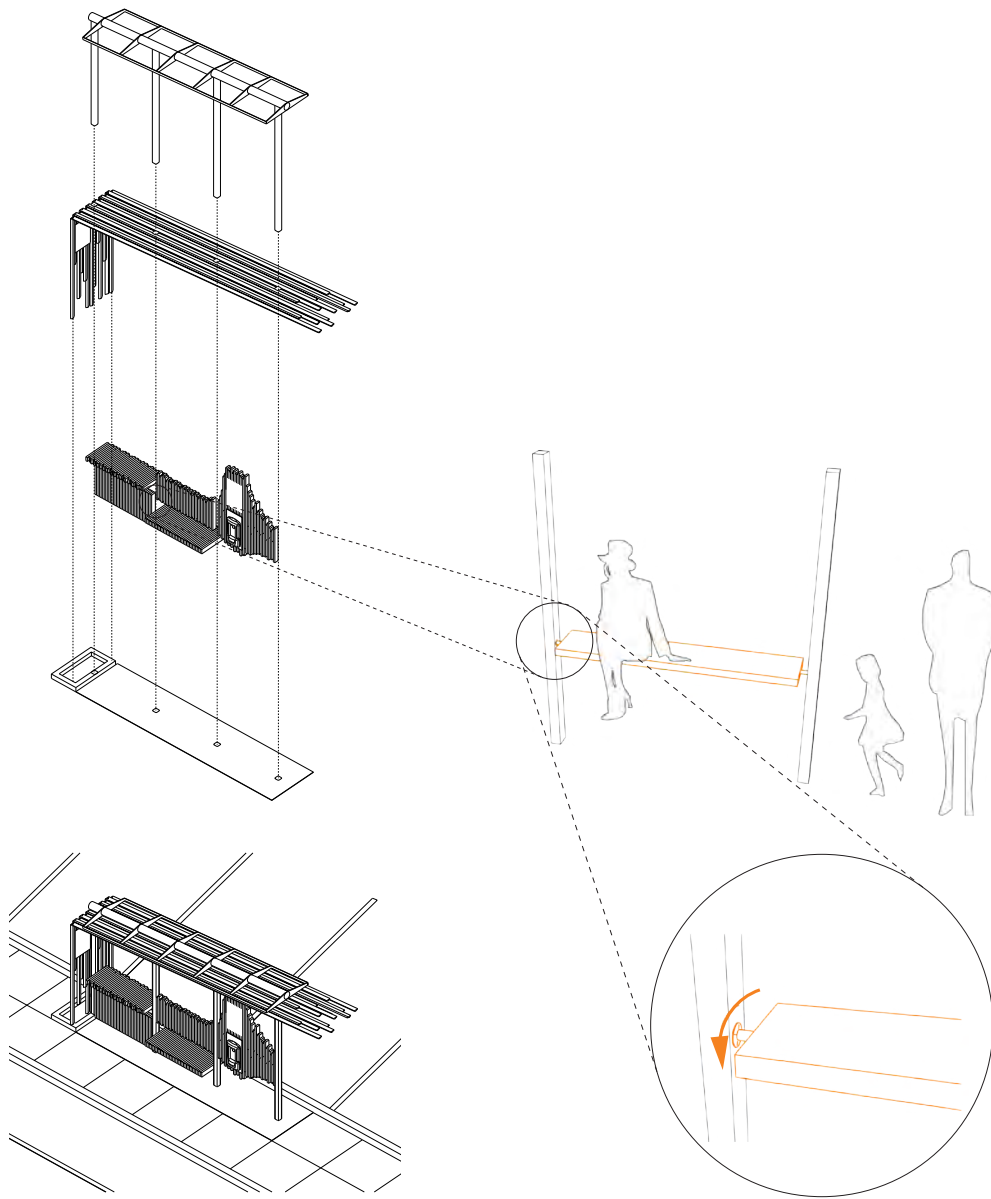

KEY POINTS:

The materials provide opportunity for community engagement as well as environmentally sustainable design.

DESIGN

MATERIALS and AMENITIES

1. Structure and Shelter

A ceiling made of aluminum channels diffuses the sunlight, collects rainwater for plantings, and allows for open air flow.

2. Amenities

hydration station

multipurpose rotating benches and counter tops

route information and schedules

lockable storage and stands for micro retailers

green space

1.

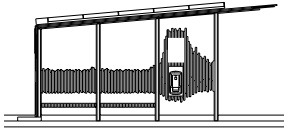

Diffuse

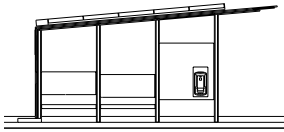

Square

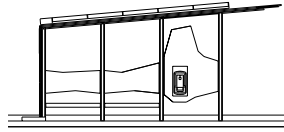

Iceberg

2.



Western Red Cedar



White Cedar



Teak

3.

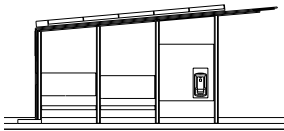
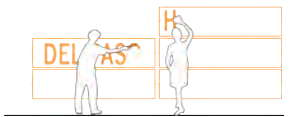

COMMUNITY ENGAGEMENT

SHAPE, MATERIAL and GRAPHICS SELECTION

1. Shape Selection

Community or organization decides between the 'diffuse,' 'square,' or 'iceberg' shapes.

2. Material Selection

Community or organization chooses western red cedar, northern white cedar, or teak for the material of the chosen shape.

3. Community Graphic Design

The addition of art and/or a graphic is completed by a local artist or organization to represent the neighborhood. This could be as simple as naming the neighborhood ('Del Paso Heights') in which the bus stop is located so that the identity of the area becomes important.

COMMUNITY ENGAGEMENT

DIAGRAM OF TRANSFORMATION

This diagram represents the multiple configurations of the bus shelter design made possible by the rotating benches and counters. The community can choose to set it up as:

1. shelves for books
2. pin-up wall for posters
3. benches for resting
4. countertops for exchange

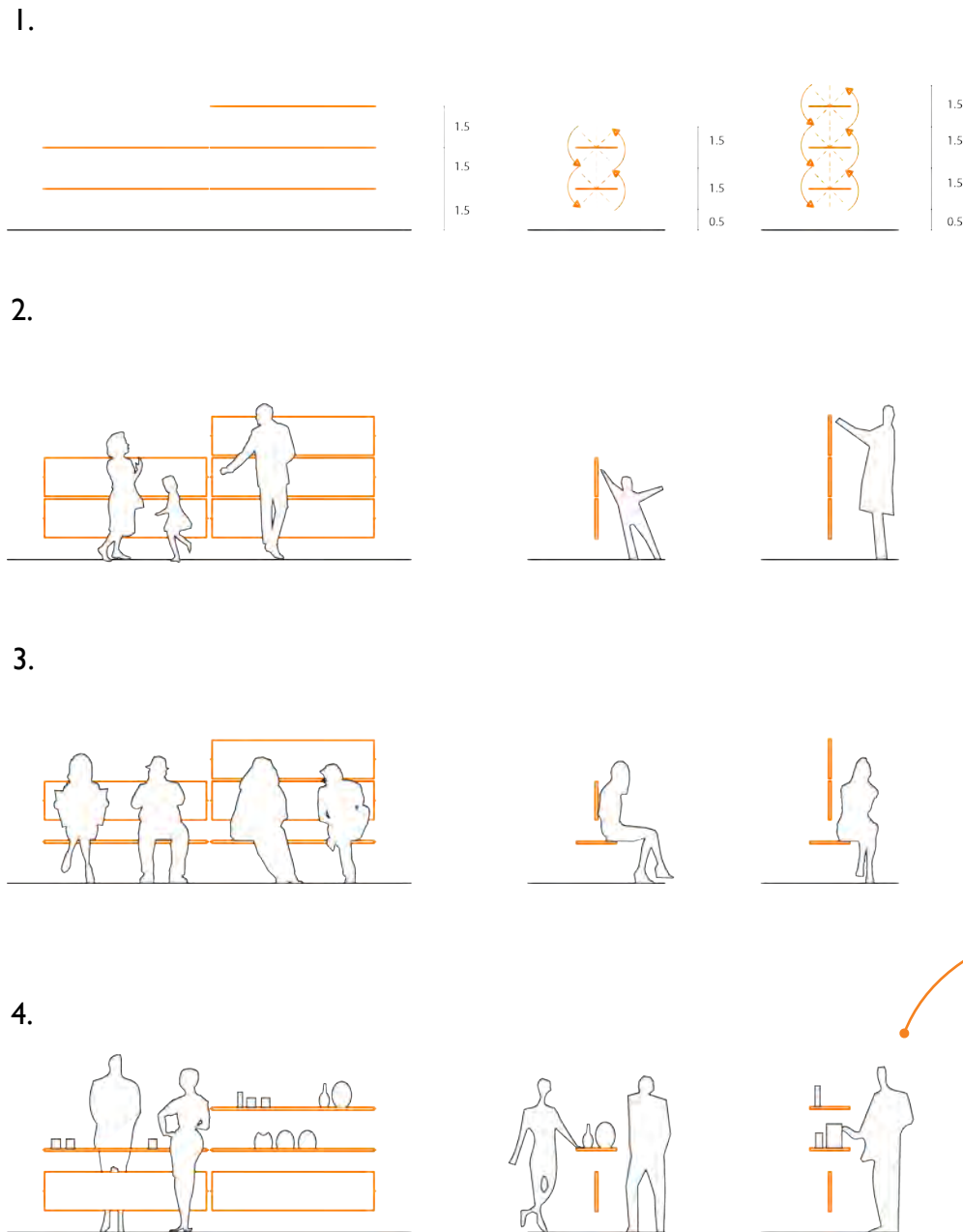



SAFETY

SAFE SPACE FOR PASSENGERS

Additional safety measures improve the quality of a bus stop. The Diffuse stop incorporates lighting, transparency, and visibility in its design.

BUILT PRECEDENTS

DP Architects Bus Stop

“This concept shelter in Jurong East Central is a test-bed for the reinvention of bus stops as meaningful social nodes. Designed as a kit of parts, the bus stop integrates slices of distinctive environments such as a garden, library, gallery, bike park, playground, kiosk, energy farm; and offers civic services such as media boards, WiFi connectivity, phone charging, wayfinding and more. The array of social and environmental plug-ins at the bus stop provides the community with diverse possibilities and opportunities for appropriation, to purposefully reshape the bus stops in their own neighborhoods, and to respond to each of their surrounding contexts, unique settings and evolving needs.”

<http://www.dpa.com.sg/projects/project-bus-stop/>



KEY ELEMENTS:

The bus stop design meets all required codes and regulations while also providing additional amenities.

The design considers a bus stop as a community asset.

The bus stop design exists in a sustainable manner while improving transit experience.

FACTS:

Location: Jurong, Singapore

Designer: DP Architects

Project Stakeholders:
Media Development Authority
National Environment Agency
Urban Redevelopment Authority (URA)

APPLY THIS TO A BUS STOP DESIGN:

CONSIDER FOR THE DESIGN OF A BUS STOP IF:

- the site would benefit from additional amenities
- the site is along a transit line with a recent increase in ridership
- if funding becomes available for design of a socially and environmentally responsible transit stop

BUILT PRECEDENTS

DP Architects Bus Stop

1 - TYPES

The bus stop provides the basic requirements of shelter, signage and shading while including a variety of additional amenities.

2 - SPACING AND LOCATIONS

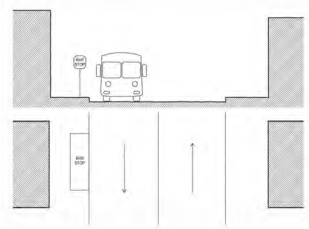

See 2.2- Curbside Stop

3 - DESIGN CHARACTERISTICS

The stop is on a spacious platform that provides space for the additional bus stop amenities while also meeting the requirements of accessibility, platform height, platform width, and loading capacity. In addition to this, the stop shelter is made in consideration of durable materials, security, lighting, and visibility.

4 - AMENITIES AND CONCERNS

The following pages illustrate the multiple design responses to concerns of the bus stop needs.



Signage



Shelter



Shade



ADA



Lighting

BUILT PRECEDENTS

DP Architects Bus Stop

The bus stop design provides additional amenities such as:

- library exchange
- electronic library code/scan
- swings



News & Book
Sharing



Seating - Swings!

"We also hope this project will encourage more fellow professionals to step forward and collaborate actively in the design of our everyday public spaces, as well as inspire the community to take greater ownership in shaping their own environments."

-Seah Chee Huang of DP Architects

BUILT PRECEDENTS

DP Architects Bus Stop

The bus stop design provides additional amenities such as:

- wifi
- real-time information screens
- interactive maps and wayfinding devices



Maps



Tickets



Wi-fi

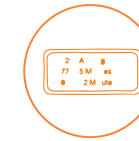

Real-Time

BUILT PRECEDENTS

DP Architects Bus Stop

The bus stop design considers sustainable elements such as:

- greenroof
- solar panels
- greenspace/plantings



Sustainability



Greenspace

BUILT PRECEDENTS

DP Architects Bus Stop

The bus stop design provides additional amenities such as:

- wifi
- electronics charging station
- restrooms
- bike and car parking



Wi-fi



Facilities

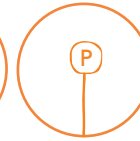

Bike and Car Parking

BUILT PRECEDENTS

Sonoran Shelters Project

“The Sonoran Shelters project is comprised of two bus shelters that serve as the transit center for the new Civic Center in the Town of Marana, Arizona. The designs aspire to dignify the use of public transportation by prioritizing use and environmental performance. The shelters are designed to mitigate the extreme environmental conditions of the region: seasonally high temperatures, intense sunlight and torrential downpours. They utilize a horizontal louver system calibrated to eliminate early morning and late afternoon solar exposure between the vernal and autumnal equinoxes. The louvered enclosures minimize vertical surfaces typically prone to graffiti and are designed to enable effective rider-driver visibility and situational awareness for occupants. Expansive roofs are employed to maximize protection from rain and water shed. Prominent gutters and rain chains are integrated to evoke the regional importance of water and its ephemeral presence in the arroyos endemic to the region.”

<http://www.dbxchange.eu/node/1301>



KEY ELEMENTS:

The bus stop design meets all required codes and regulations while also providing additional amenities.

The design considers a bus stop as a community asset.

The bus stop design exists in a sustainable manner while improving transit experience.

The bus stop was part of a design build project with the students of The University of Arizona.

FACTS:

Location: Marana, Arizona

Designer: Christopher Trumble + Students

Project Stakeholders:
University of Arizona
Town of Marana
Regional Transportation Authority
Town of Marana

BUILT PRECEDENTS

Sonoran Shelters Project



Sustainability



Greenspace

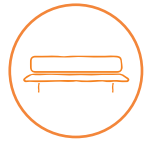

Seating



Maps



BUILT PRECEDENTS

Sonoran Shelters Project

1 - TYPES

The bus stop provides the basic requirements of shelter, signage and shading while considering an environmentally and socially sustainable approach.

2 - SPACING AND LOCATIONS

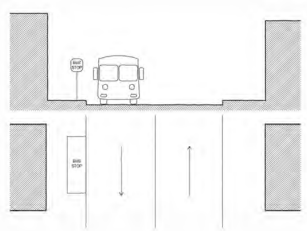

See 2.2- Curbside Stop

3 - DESIGN CHARACTERISTICS

The stop is on a spacious platform that incorporates site specific decisions in relationship to sun, water shed, and regional materials. The bus stop also incorporated a fabrication class taught by Jean-Luc Cuisnier for the material assembly.

4 - AMENITIES AND CONCERNS

The following pages illustrate the multiple design responses to concerns of the bus stop needs.

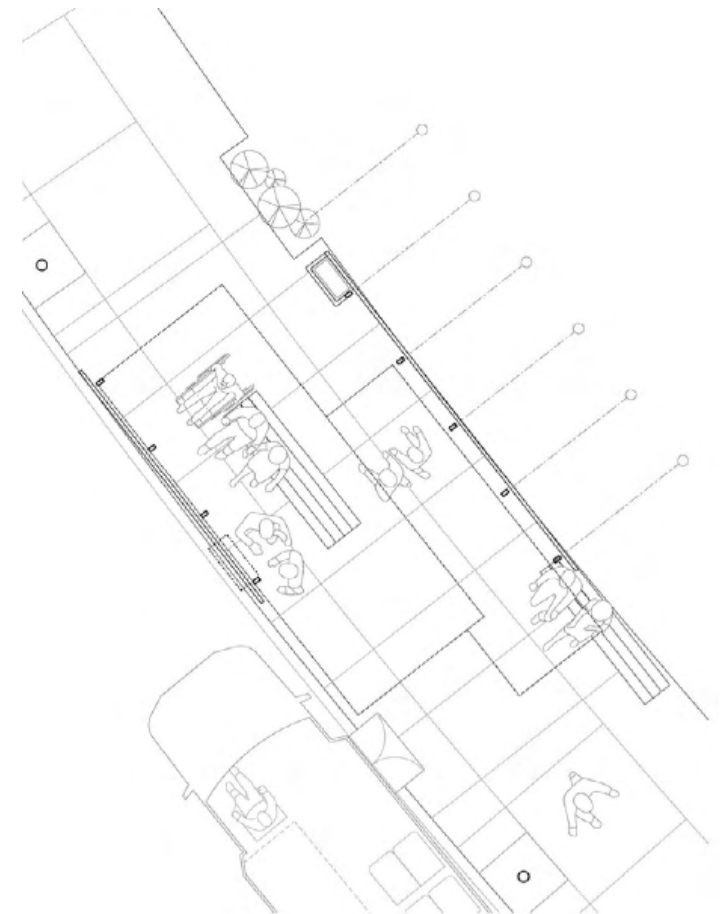

Signage



Shelter



Shade



ADA



Lighting

BUILT PRECEDENTS

Sonoran Shelters Project



Rain chain



Material detail

BUILT PRECEDENTS

Sonoran Shelters Project

The stop considers factors such as driver and passenger visibility as well as security elements such as lighting and shelter.



BUILT PRECEDENTS

Sonoran Shelters Project



Relationship to the approaching bus and street condition.

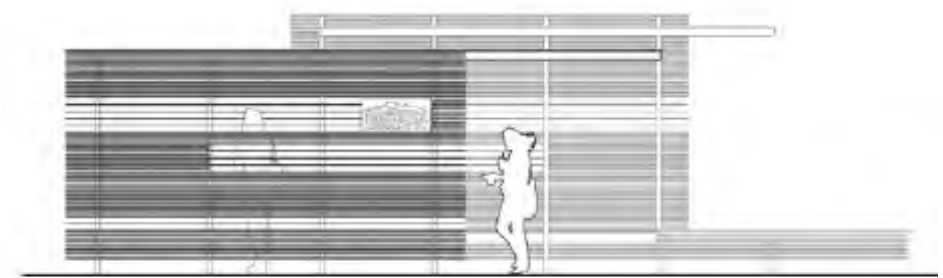
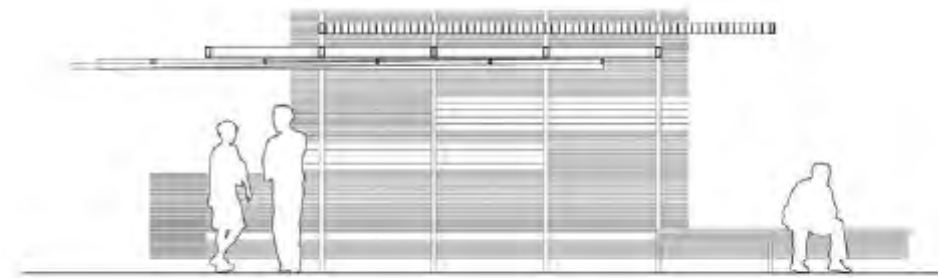
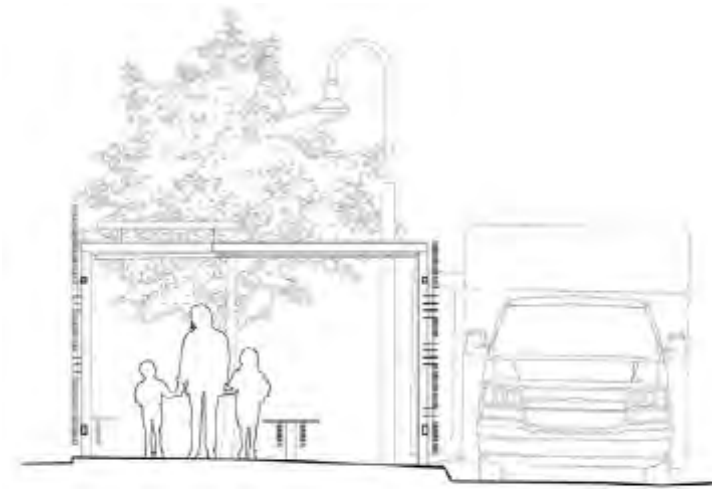

PRECEDENTS

Sacramento Philharmonic and Opera Bus Stop

"A new music venue opened ... in downtown Sacramento—in a bus shelter.

The partially enclosed bus stop at I 4th and L streets—steps from the Sacramento Community Center Theater—has been converted into "The World's Smallest Concert Hall," and until the end of November, passersby and those waiting for public transit can sit in one of four red theater seats and listen to arias from operas like Don Giovanni and The Barber of Seville and symphonic pieces from composers such as Mozart, Brahms and Tchaikovsky." -Jessica Rine, Sactown Magazine



KEY ELEMENTS:

- Stop creates a mini-concert experience for waiting passengers
- Designed to raise awareness of the regional arts scene
- Draws attention to the cultural aspects of the city by reaching out to daily commuters in a creative way

FACTS:

Location: Sacramento, California

Project Stakeholders:

Sacramento Philharmonic

Sacramento Regional Transit (SacRT)

ClearChannel

Sactown magazine

The B Street Theatre

Allied Custom Upholsters

PRECEDENTS

Sacramento Philharmonic and Opera Bus Stop



News & Event
Sharing



Seating - concert!



PRECEDENTS

Sacramento Philharmonic and Opera Bus Stop



News & Event
Sharing

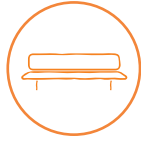

Seating - concert!



*How do you
make*

impact

*when
time,
resources,
and money
are
limited*

CHAPTER 6: BUS STOP INTERVENTIONS

This chapter will diagram the various opportunities to redesign existing bus stops along a transit line. While new bus stops are ideal in terms of design opportunity, many improvements can be made to existing stops on transit lines. The addition of program or branding (or a tree!) makes an existing stop much more appealing to a community. These efforts increase ridership and make a more beautiful city.

BUS STOP TYPES

Three common bus stop types along the bus routes of the Sacramento, California Regional Transit lines provide opportunity for design intervention. Community engagement and design of the interventions establishes a sense of place and identity.

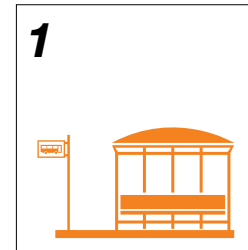

Type 1 - Shelter

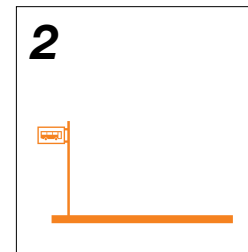

Type 2 - Sign

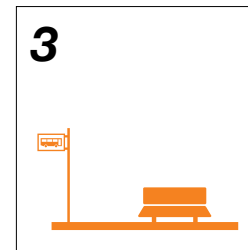

Type 3 - Bench

LINE 2 : EXAMPLE STOPS

Multiple stops along the Sacramento Regional Transit lines would benefit from design intervention. These stops along line 2 represent *examples* of a design process that could be applied to a variety of stops throughout Sacramento. The following design proposals address the basic needs of a stop while considering additional amenities to promote healthy and sustainable communities. For example, the interventions address healthy living through proposals of biking amenities, a community bookshare or promotion of local food truck businesses. Thus, through small changes, the stop becomes an important element to the members of the community.

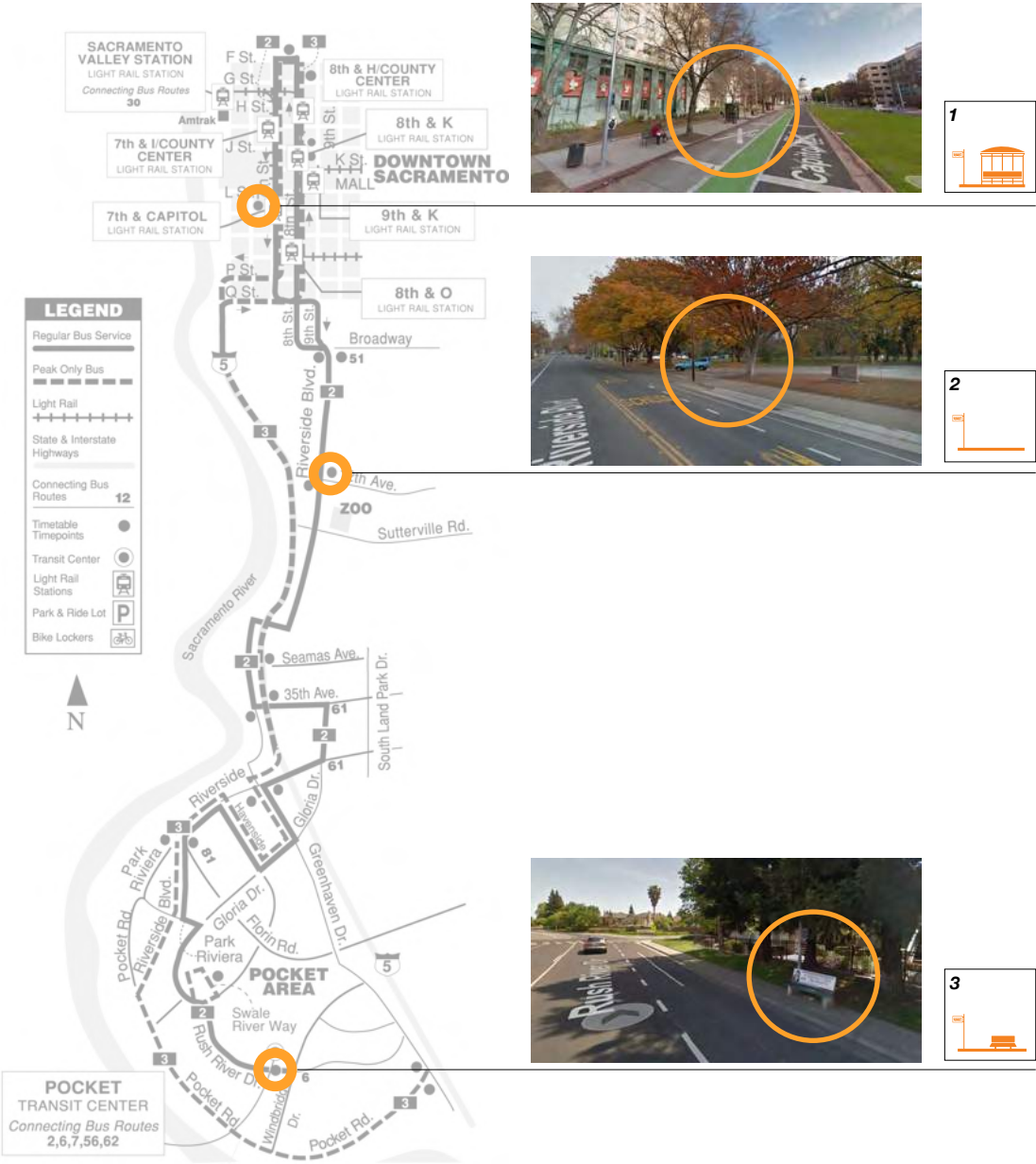

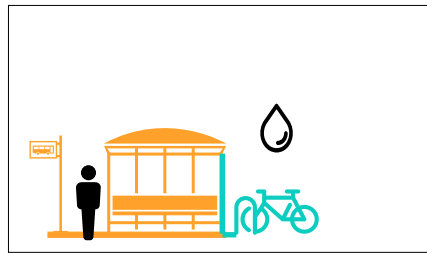
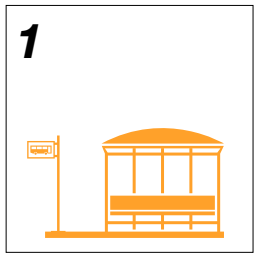

- Engage community to identify:
- best bike commuter routes
 - local biking organizations/events
 - best identity/placemaking strategies

Bike + Rainwater Hydration Station

- Enhance best routes for biking
- Provide a bike lock up, bike pump, and hydration station for commuters
- Paint stations bright colors/with artwork/super graphics to indicate pathways, stops, and neighborhoods

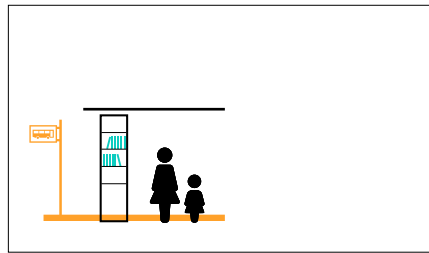
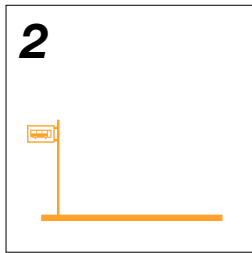

- Engage community to identify:
- best neighborhoods for reading stops
 - local libraries
 - best identity/placemaking strategies
 - local organizations
 - local schools

Library Stop

- Establish a network of libraries for community book exchange
- Provide reading/entertainment for waiting passengers
- Connect with libraries and schools for design-build of library stops

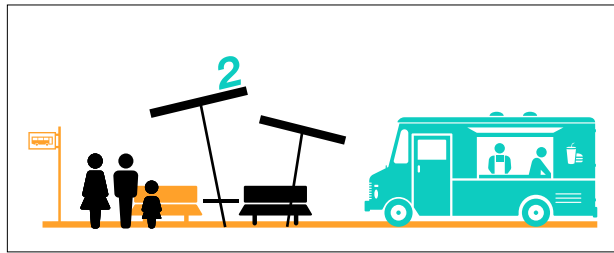
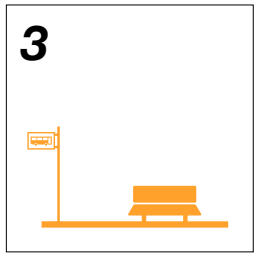

Engage community to identify:
-best stops for on-the-go food
-best stops for local food businesses
-best identity/placemaking strategies

Food Truck Stop

- Promote local food trucks/restaurants
- Provide grab'n'go food for passengers
- Make transportation more lively and desirable

LINE 15 : EXAMPLE STOPS

Just as with the examples of line 2, the potential design of line 15 stops could be implemented along many of the transit routes. The following stops consider the well-being of the people of Sacramento by addressing the air quality, access to healthy food, and promotion of local art and artists.

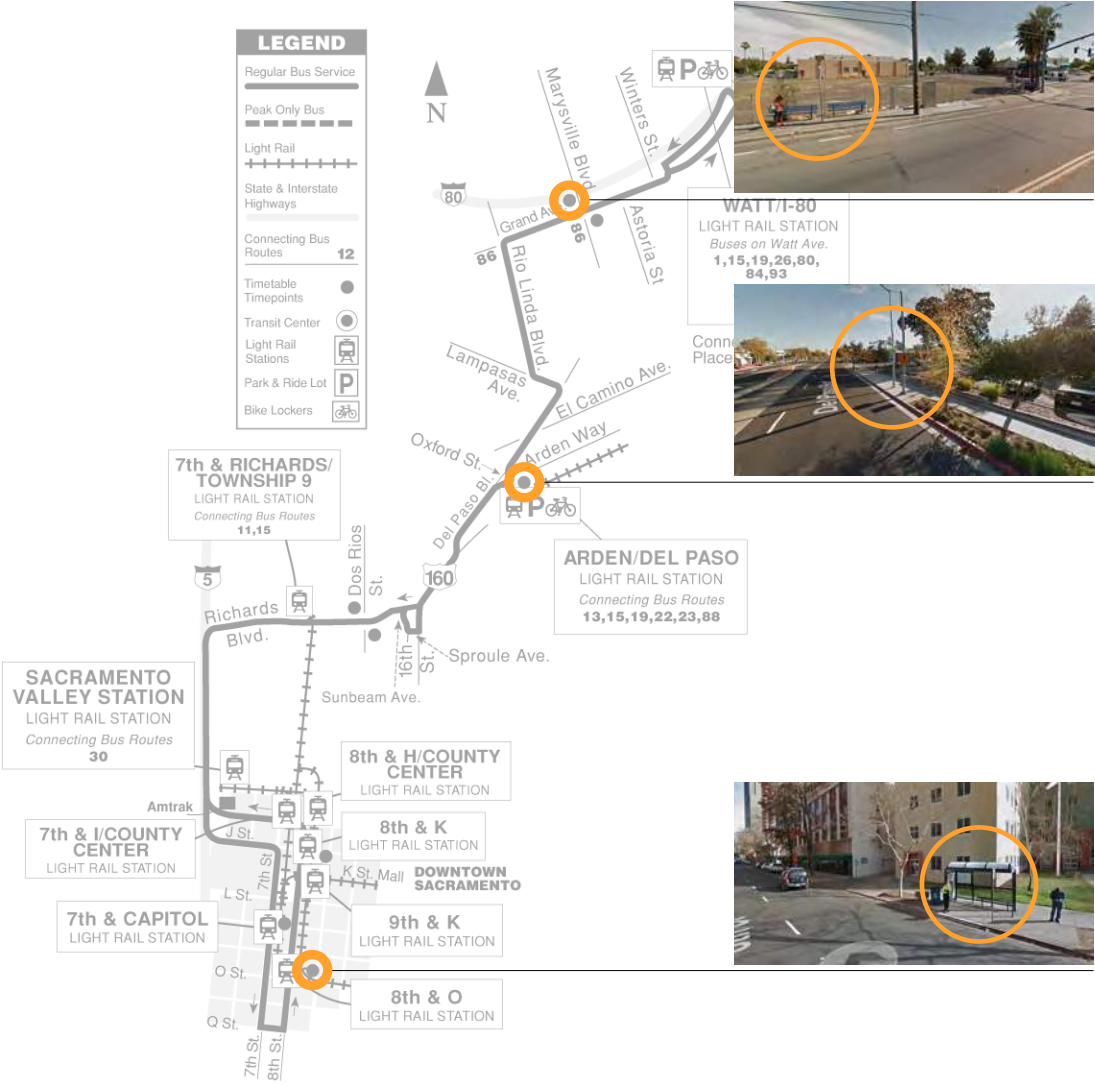

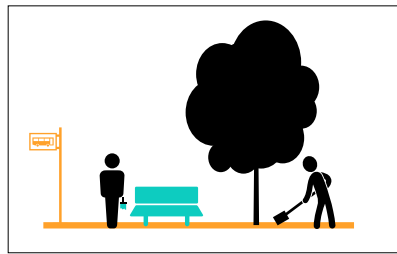
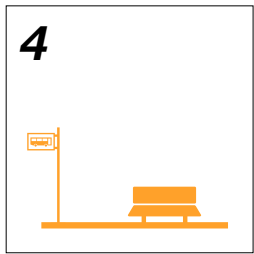

Engage community to identify:
-local community organizations
-local tree nurseries
-best identity/placemaking strategies
color, graphics, etc.

Bench + Tree Stop

- Provide trees for shade at uncovered stops
- Plan community tree planting and bench painting charrette for multiple interested organizations
- Paint station benches bright colors and/or with artwork/super graphics to indicate stops and the identity of neighborhoods along the route

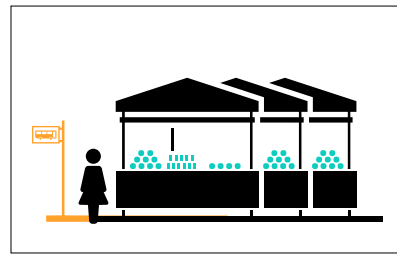
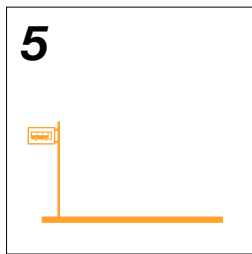

Engage community to identify:

- food deserts
- local community gardens
- best identity/placemaking strategies
- local vendors/businesses

Farmers Market Stop

- Establish a network of farmers markets and pair with food desert located bus stops/routes
- Provide weekly fresh food markets at bus stops
- Provide convenient access to food for commuters

*see MARTA Fresh Market for a successful precedent to this concept

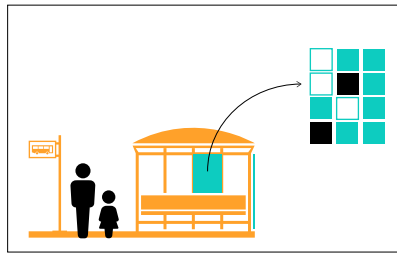

Engage community to identify:
-local artists
-connect with elementary or middle schools
-collaborate best identity/placemaking strategies

Mosaic Stop

- Pair local schools with bus stops
- Provide tiles for children to design as their own
- Local organizations and/or artists work together to create and install cohesive mosaics on the existing bus stop shelters

*see King Co. Metro Mosaic Stops for a successful precedent to this concept

LINE 67 : EXAMPLE STOPS

The bus stops along line 67, like many throughout Sacramento, would benefit from better shading, wayfinding and information. As a node within a network, a bus stop provides a perfect opportunity for wayfinding through branding. A stop can become a tool for input from passengers, an informational hub, or a source of wifi-access while waiting.

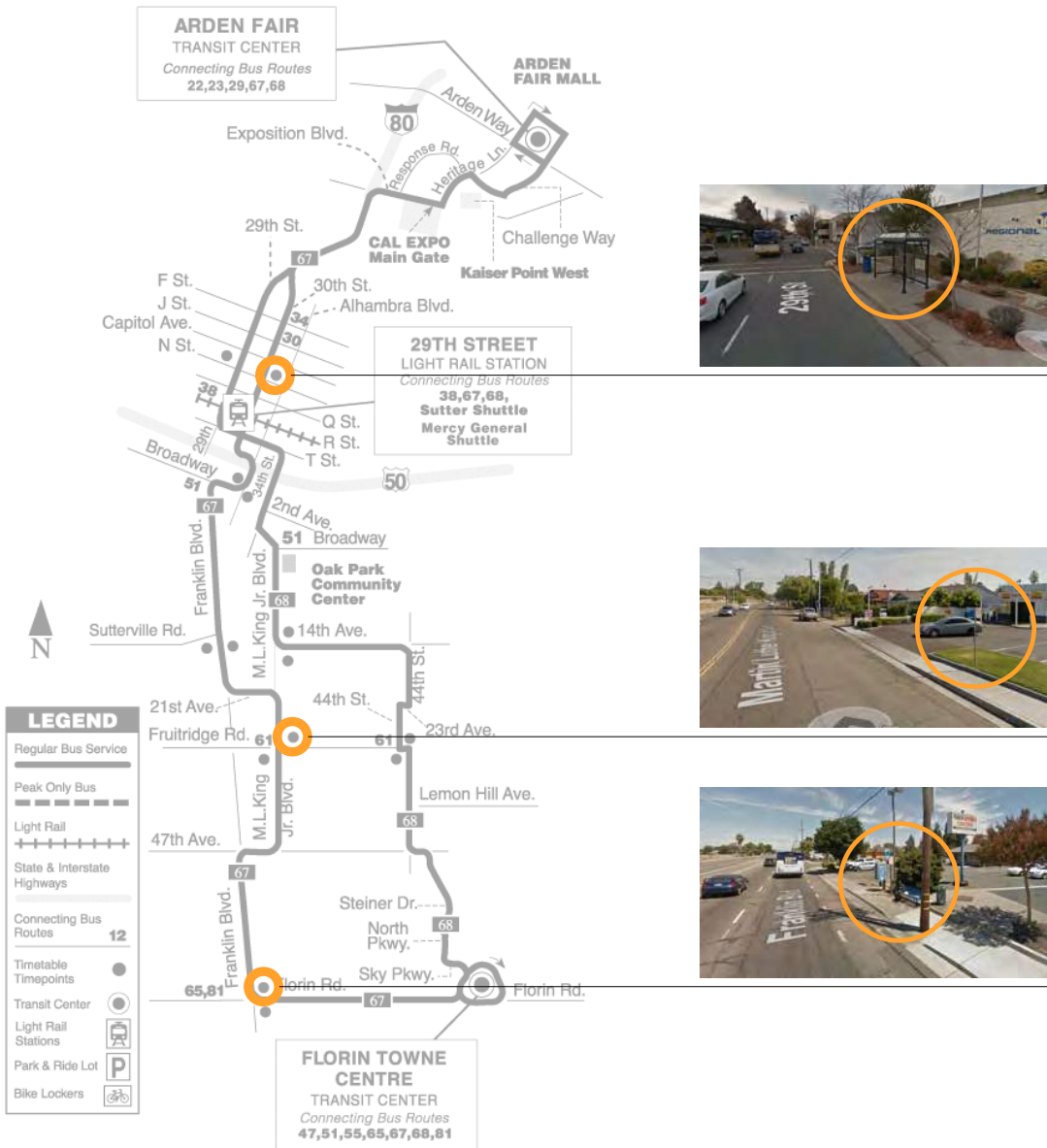

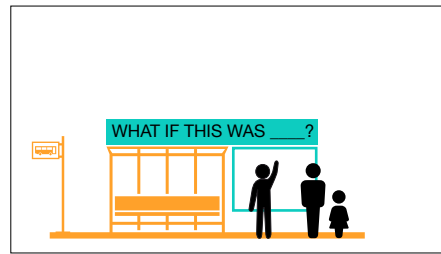
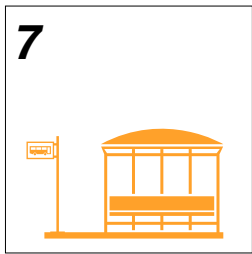

Engage community to identify:
-local community organizations
-best identity/placemaking strategies
-color, graphics, etc.
-local organizations

Bus Stop Dialogue

- Attach suggestion board to existing bus stops
- Paint station shelters bright colors/with artwork/super graphics to indicate stops and the identity of neighborhoods
- Select engagement question (i.e. "What if this was_____?")
- Collect feedback from all participants
- Analyze feedback for design opportunities

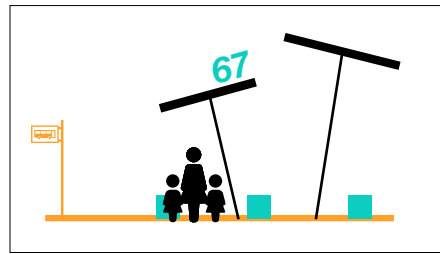
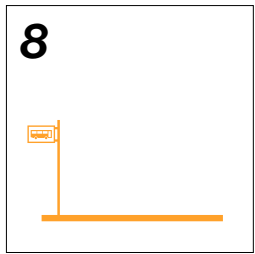

Engage community to identify:
-bus stops without shade and seating
-best identity/placemaking strategies
color, graphics, etc.

Sunbrellas Stop

- Provide different shading devices for exposed bus stops
- Design seating for sunbrellas
- Paint seating/shading devices bright colors/with artwork/super graphics to indicate stops and the identity of neighborhoods

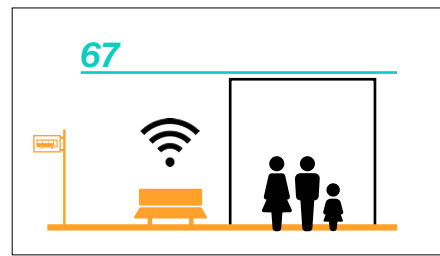
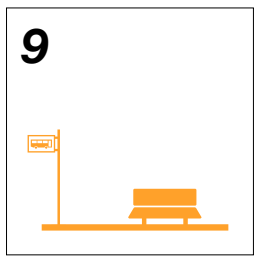

Engage community to identify:

- best stops for shelter
- best stops for incorporation of
- wayfinding best identity/placemaking strategies, color, graphics, etc.
- local organizations

Wayfinding + Wifi

- Create a series of way-finding elements to pair with bus stops
 - colors
 - sculptures
 - local artwork
 - informational facts about city/neighborhood
 - etc.
- Provide wifi at bus stops for waiting passengers
- Increase overall connectivity and service information

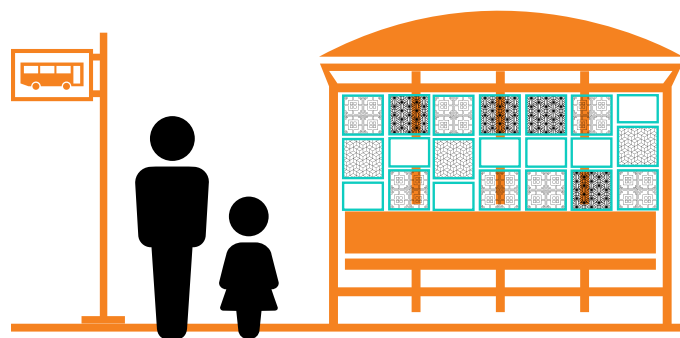

MOSAIC STOP

A series of collaborative mosaic designs for existing bus stop shelters creates a sense of place for the neighborhood. Creating the mosaics provides opportunity for engagement with schools and local artists while also establishing an identity that impacts the rest of the neighborhood. Each piece of the mosaic represents an individual and together makes for a more vibrant sense of place in public space.

Steps:

1. Choose a bus stop for intervention
2. Establish a connection with local elementary schools and explore opportunities for donation of blank tiles.
3. Plan a tile painting day at the elementary school (festival, within an art class, etc.)
4. Connect with local artists to establish a lead designer.
5. Artist collects tiles from schools to create a mosaic mural composition.
6. Mosaic is then installed to existing bus shelter.



Choose a bus stop for intervention.

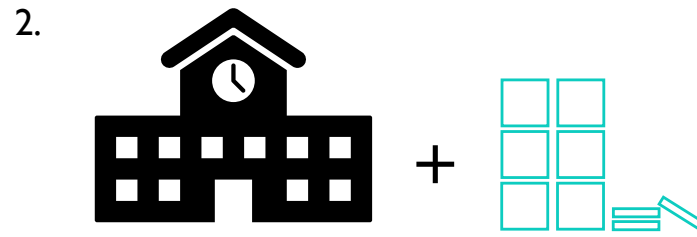

2. Establish a connection with local elementary schools and explore opportunities for donation of blank tiles.

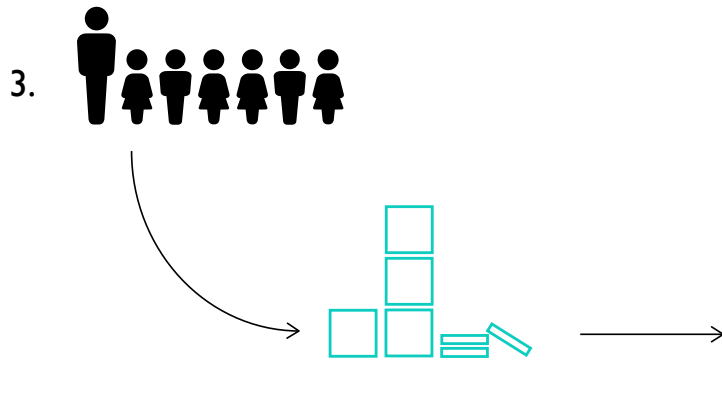

Plan a tile painting day at the elementary school (festival, within an art class, etc.)

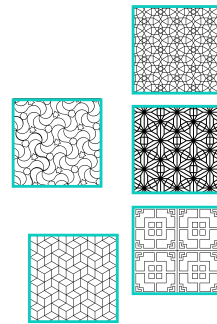

Connect with local artists to have a lead designer/creator.

Artist collects painted tiles from schools and creates a mosaic mural composition to apply to the bus stop.

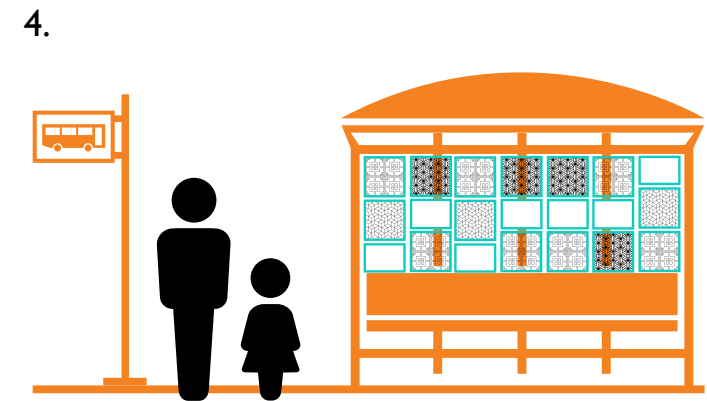

APPENDIX A: CONTEXT ANALYSIS OF SACRAMENTO

This chapter will cover the context in which the theories behind transportation design could transform the underserved neighborhoods of Sacramento, California. The initial research to establish potential projects, locations, and sites produced demographic information that highlighted key concerns of the underserved neighborhoods. The census data revealed an overall lack of access to resources that formulated the scope of work. Resources such as fresh food, medical services, legal services, and so on, were difficult to reach for significant portions of the city. The following diagrams and maps illustrate the overarching issues.

KEY POINT:

Census analysis confirmed that Sacramento would benefit from better public transportation in order to connect residents to services and amenities.

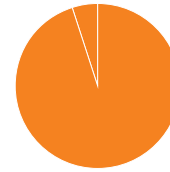

MAJORITY DO NOT TAKE PUBLIC TRANSPORTATION

Commute via Public Transportation

Block Group 1 : 7%

Block Group 2 : 5%

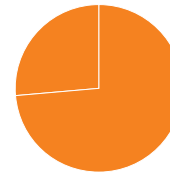

MAJORITY COMMUTE BY CAR

Commute via Car

Block Group 1 : 86%

Block Group 2 : 63%

IDENTIFIED PROBLEMS

Census data analysis contributed to interpreting the city's problems. The Fall Term Design Studio at Portland State University researched the accessibility to resources and services in the city. The Marysville Boulevard/Grand Avenue intersection in Del Paso Heights and Franklin Boulevard in South Sacramento represent areas affected by a variety of problems. The California Environmental Protection Agency determines these areas as underserved. The zip code of an individual's home has a far greater impact on their well-being than often perceived. As noted before, identified problems consist of access to healthcare, legal services, healthy food, safe public spaces, functional transportation, and so on. In addition to this, the cost of living in comparison to the median income of these areas solidified the need for design intervention. Improvement to transportation provides design solutions to many of the issues faced by the neighborhoods of the city of Sacramento.

LIMITED ACCESS TO SERVICES

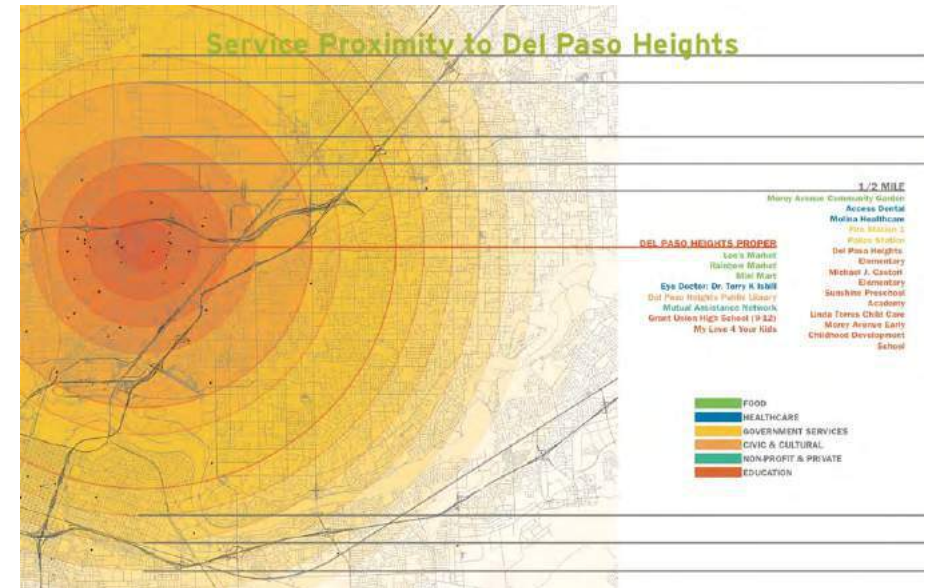

DIFFICULTY ACCESSING SURROUNDING SERVICES

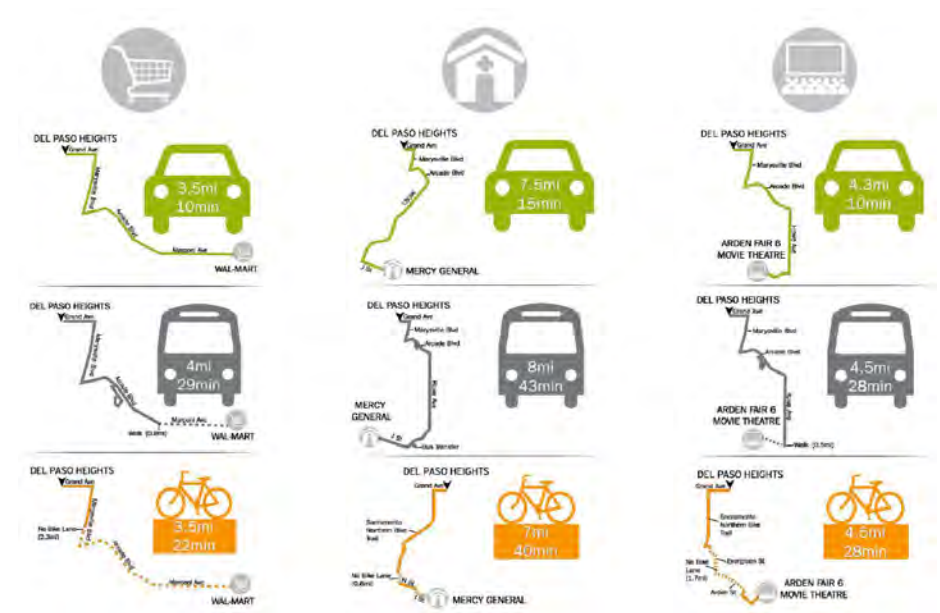

IDENTIFIED PROBLEMS

An acceptable walkability measure is $\frac{1}{4}$ of a mile distance to services in an urban condition. Census data revealed transportation 'gaps' in the current as well as proposed city conditions. In general, the buses are seen as running infrequently, with too few shelters, and not enough attention to safety of women and children. The CPID conducted a community engagement event at the 2014 Harvest Festival in Del Paso Heights. Concerns about transportation were confirmed by the design surveys, conversations, and design charrettes completed. The transportation feedback concluded that cars were most accessible and public transit was least utilized. Thus, CPID proposed design interventions focusing on ways to increase ridership and improve the quality of public transportation.

LIMITED ACCESS TO SERVICES



KEY POINTS:

The communities of South Sacramento and Del Paso Heights suffer from lack of access to services via adequate transportation.

POTENTIAL SITES



SITE ONE

1. The Marysville Blvd. and Grand Ave. intersection provides opportunity for a vibrant community space that considers the city's future growth. An existing, sun-exposed bus stop, reinvented as a new community gate would give identity to the neighborhood through its potential for a distinct visual presence along the street. In addition to its placemaking potential, the site is near a new Viva Market, the Greater Sacramento Urban League, Grant Union High School, the US Post Office, as well as other locally owned small businesses. Bus Routes 15 and 86 provide connections to Downtown Sacramento and the Sacramento Light Rail.

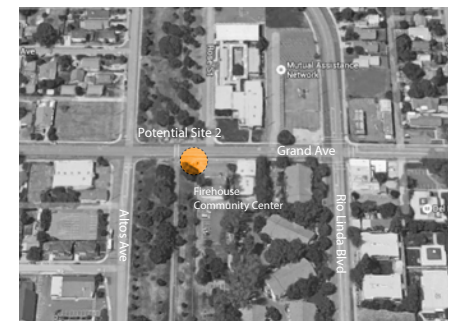

SITE TWO

2. The second proposed site is mid-block on the south side of Grand Ave. between Rio Linda Blvd. and Altos Ave. The proximity to neighborhood amenities such as the popular Firehouse Community Center, the bike trail and the Mutual Assistance Network make this site appealing for design intervention. The stop is only a sign post without seating or shelter of any kind. While the stop only services one bus route, the creation of a more suitable bus stop would improve ridership.

APPENDIX B:

'w/sacramento' interactive tool

Beginning in the Spring of 2014, the Center for Public Interest Design (CPID) at Portland State University (PSU) began working with the Sacramento Area Council of Governments (SACOG) to strategically address issues within underserved neighborhoods in Sacramento through partnerships with active organizations in those communities. The CPID has been conducting research, creating design proposals, and identifying tools and opportunities to facilitate action in the neighborhoods in order to build capacity among stakeholders. This proposed online tool, 'w/sacramento,' seeks to document ideas, concerns, and opportunities identified by community members within their neighborhoods. The results of the online tool allow the concerns to be addressed and result in positive change in the area. The CPID has customized this tool using the Local In platform developed by their partners at Ecosistema Urbano, an international architecture and urban design firm. The following slides represent the proposal for the interactive website interface.

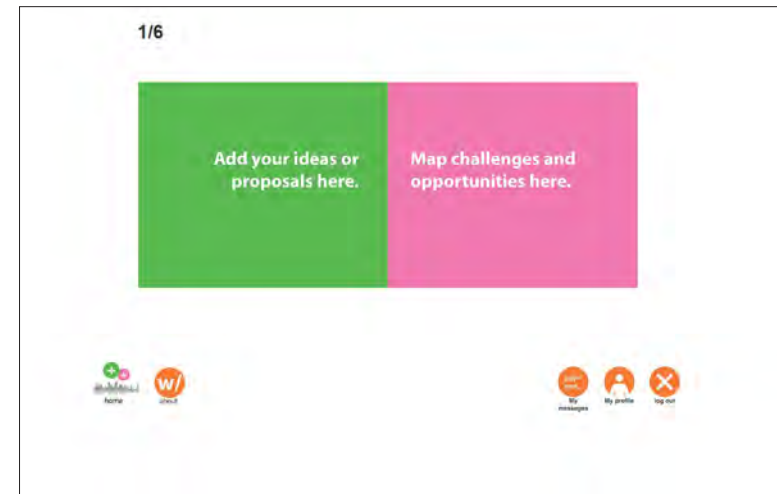
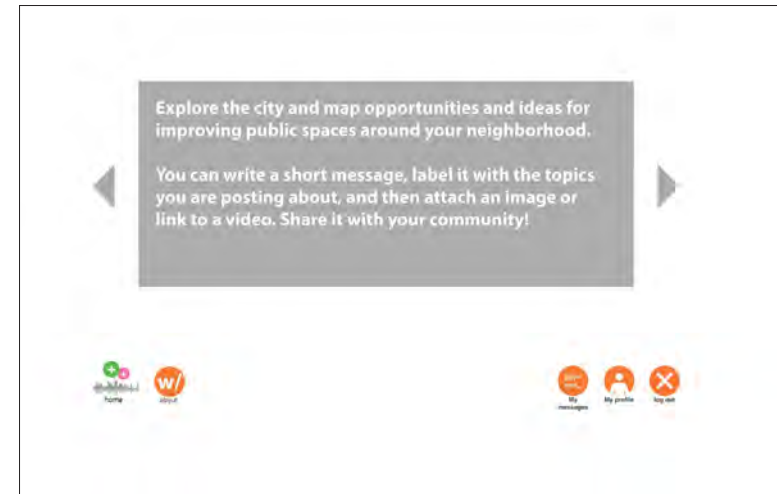

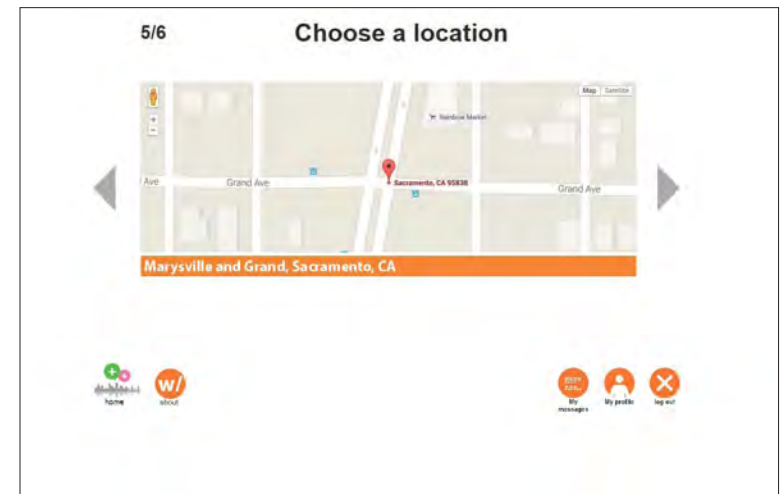
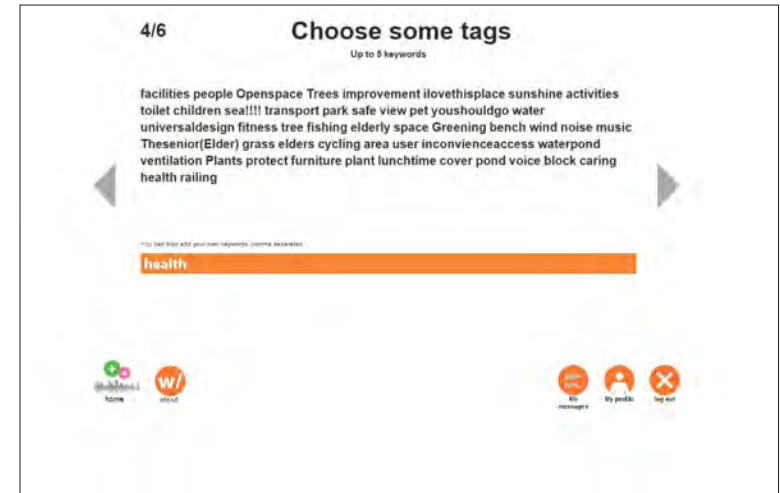

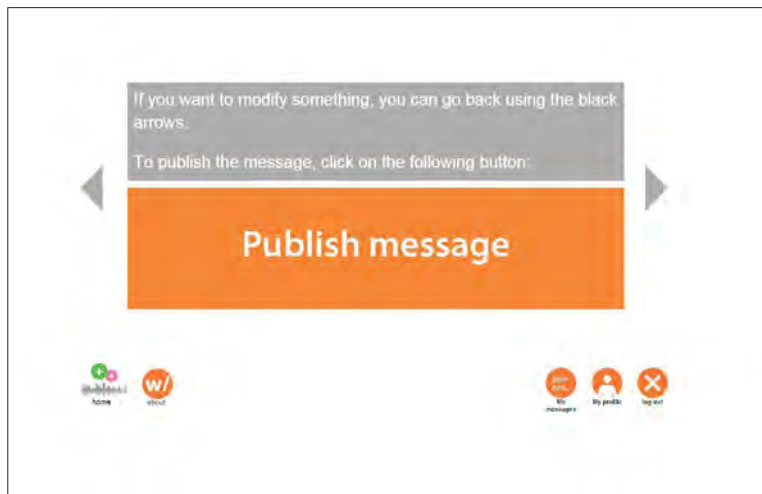
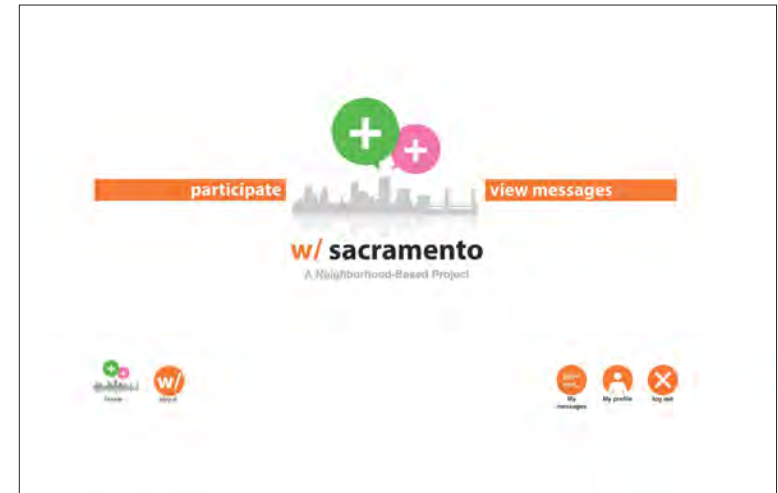

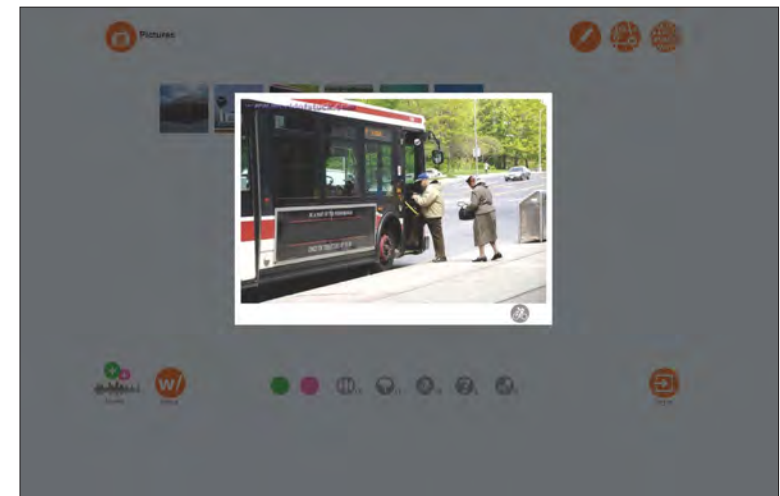
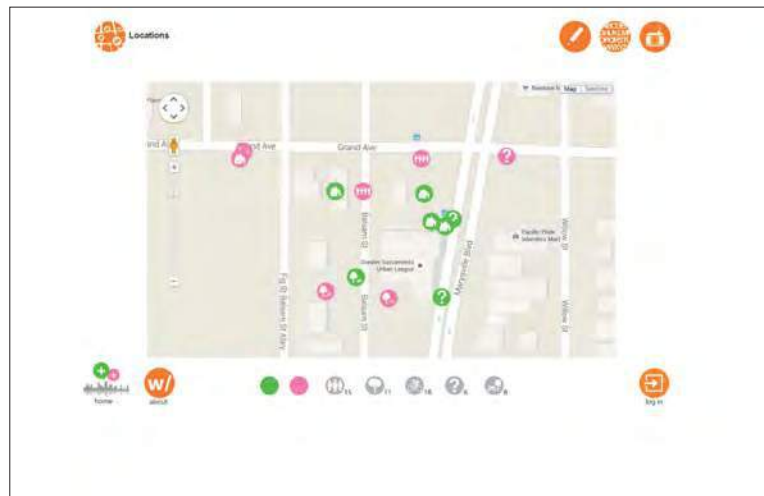
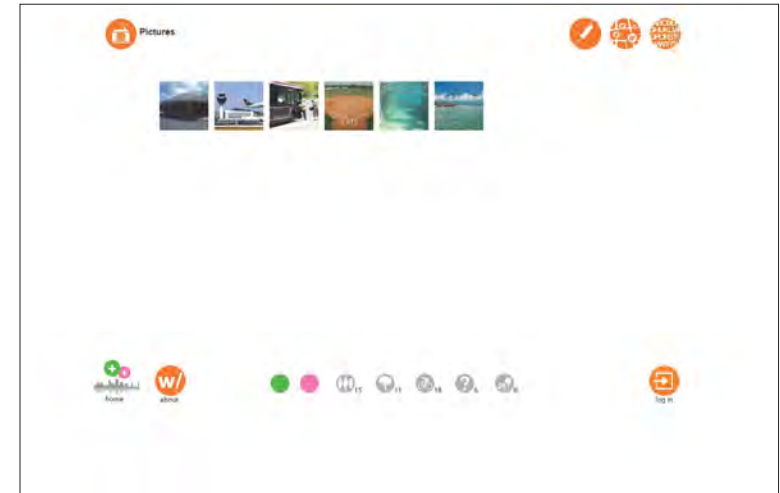

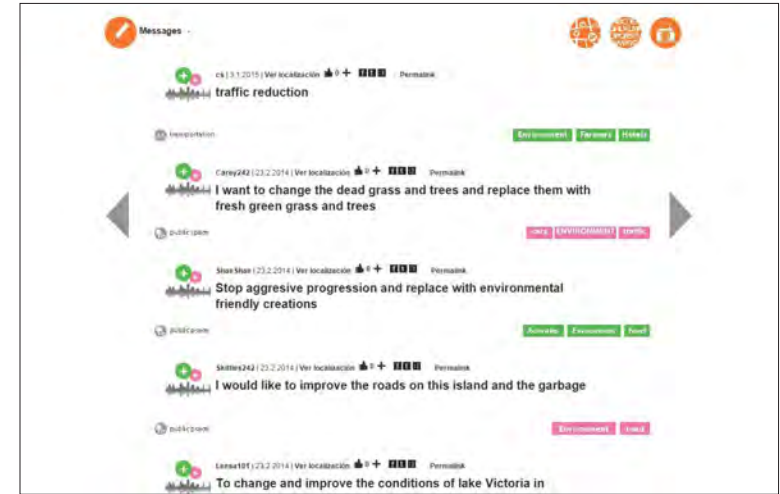
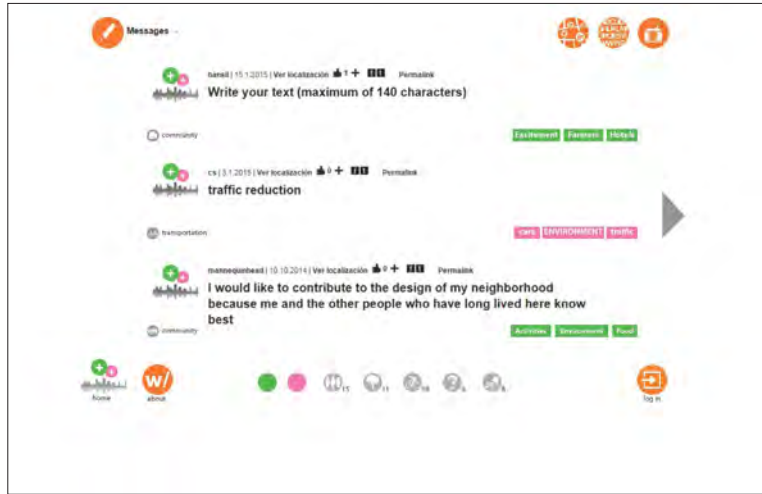

TRANSIT GUIDE

REFERENCES

Artplaceamerica.org. (2017). The Porch at 30th Street Station. [online] Available at: <http://www.artplaceamerica.org/funded-projects/porch-30th-street-station>. [Accessed Jun. 2017].

Beforeidie.city/about/. Before I Die. [online] Available at: <http://beforeidie.city/about/>. [Accessed Aug. 2017].

Bell, Bryan, and Katie Wakeford. Expanding Architecture: Design as Activism. Metropolis Books, 2008.

Bostonmagazine.com. (2013). Boston Magazine. [online] Available at: <http://www.bostonmagazine.com/news/blog/2013/09/12/boston-parklets-mission-hill-jamaica-plain/>

Boston.com. (2013). Parklets. [online] Available at: <http://www.boston.com/news/local/blogs/starts-and-stops/2013/09/10/parklets-debut-and-mission-hill-but-whats-with-the-price-tag/iGnYsvsJWfhkVz23eMjtjO/blog.html>

Cfmatl.org/marta/. Fresh Marta Market. [online] Available at: <http://cfmatl.org/marta/>. [Accessed Jun. 2017].

Cityofsacramento.org. (2017). MAJOR ENCROACHMENT/PLAN CHECK. [online] Available at: <https://www.cityofsacramento.org/Public-Works/Engineering-Services/Permits/Plan-Check> [Accessed Sep. 2017].

Cityofsacramento.org. (2017). Transportation. [online] Available at: <https://www.cityofsacramento.org/-/media/Corporate-Files/DOU/Specs-Drawings/Transportation.pdf?la=en> [Accessed Sep. 2017].

Cityofsacramento.org. (2017). Community Gardens. [online] Available at: <https://www.cityofsacramento.org/ParksandRec/Parks/Specialty-Parks/Community-Gardens>. [Accessed Jun. 2017].

Dezeen.com. (2017). Escalé Numerique. [online] Available at: <https://www.dezeen.com/2012/07/05/escalé-numerique-by-mathieu-lehanneur-and-jcdecaux/>. [Accessed Jun. 2017].

Exploratorium 'Ciencia Publica' Parklet / Image by Stella Kim

Hamdi, Nabeel. (2004). Small Change: About the Art of Practice and the Limits of Planning in Cities. Earthscan.

Hamdi, Nabeel, Housing Without Houses: Participation, Flexibility, Enablement (London: Intermediate Technology, 1995).

Hamdi, Nabeel, and Reinhard Goethert, Action Planning for Cities: A Guide to Community Practice (Chichester: John Wiley, 1997).

Hamdi, Nabeel, and Jane Handal, eds., Urban Futures: Economic Growth and Poverty Reduction, Urban management series (London: ITDG Pub, 2005).

Inhabitat.com. (2017). 'Kalvebod Waves' Waterfront. [online] Available at: <http://inhabitat.com/jds-and-klar-arkitekters-new-kalvebod-waves-waterfront-park-makes-a-splash-in-copenhagen/>. [Accessed Jun. 2017].

Kent, Ethan, for Projects for Public Spaces, "From Place to Place: Shifting the Transportation Paradigm." <https://www.pps.org/reference/from-place-to-place-shifting-the-transportation-paradigm-with-placemaking/August,2012>

Landskapsarkitekt.tumblr.com. (2017). Landscape Architecture. [online] Available at: <https://landskapsarkitekt.tumblr.com/post/148700829648> [Accessed Jun. 2017].

Metro.kingcounty.gov. (2017). Bus Shelter Mural Program. [online] Available at: http://metro.kingcounty.gov/prog/sheltermural/sm_gallery.html. [Accessed Jun. 2017].

Missionhillgazette.com. (2013). Parklet Debuts on Tremont St. [online] Available at: <http://missionhillgazette.com/2013/10/04/parklet-debuts-on-tremont-st/>

Nacto.org. (2017) National Association of City Transportation Officials. [online] Available at: <https://nacto.org/publication/transit-street-design-guide/introduction/>. [Accessed Jul. 2017].

Nelson, David of Projects for Public Places "Thinking Beyond the Station." <https://www.pps.org/reference/thinking-beyond-the-station/> May 9, 2014

TRANSIT GUIDE

REFERENCES

Park and Ride. (2017). [image] Available at: <https://s-media-cache-ak0.pinimg.com/originals/5e/ac/54/5eac54e0c786bc127aac7d6b750f58b7.jpg>. [Accessed Jun. 2017].

Pavementtoparks.org. (2017). Parklets. [online] Available at: <http://pavementtoparks.org/parklets/>. [Accessed Jun. 2017].

Plataformaarquitectura.cl. (2017). Malgrat de Mar. [online] Available at: <http://www.plataformaarquitectura.cl/cl/782983/accesibilidad-universal-desapercibida-y-a-bajo-costo-proyecto-de-urbanizacion-en-malgrat-de-mar> [Accessed Jun. 2017].

Roadsworth.com. Ground Street Painting. [online] Available at: <http://www.roadsworth.com/>. [Accessed Jun. 2017].

Rhine, Jessica. Worlds Smallest Concert Hall. Sactownmag.com, [online] Available at: <http://www.sactownmag.com/Blog/2017/Worlds-Smallest-Concert-Hall-Bus-Shelter/>

Superkilen. (2017). [image]. Available at: <https://s-media-cache-ak0.pinimg.com/originals/7d/7c/f4/7d7cf42773cf1a3dd7938972f50a6ad0.jpg> [Accessed Jun. 2017].

Universitycity.org/the-porch. (2017). What's Happening at The Porch. [online] Available at: <https://www.universitycity.org/the-porch> [Accessed Aug. 2017].

Virahsawmy, K. (2013). An oasis for the urban nomad: Public Transport Interchange as an Advocate for Publicness. Cape Town: University of Cape Town (UCT).

Walker, J. (2011). Human Transit: How clearer thinking about public transit can enrich our communities and our lives. Island Press.

OASIS Bus Stop Design - student: Nicole De Jong PSU Arch580 2014 B.D. Wortham-Galvin

LINK Bus Stop Design - student: Christopher Kulp PSU Arch580 2014 B.D. Wortham-Galvin

RHYTHM Bus Stop Design - student: Laura Beltrami PSU Arch580 2014 B.D. Wortham-Galvin

DIFFUSE Bus Stop Design - student: Matthew Rusnac PSU Arch580 2014 B.D. Wortham-Galvin

PSU Arch580 2014 B.D. Wortham-Galvin (Professor) and Theresa Apollonio (Graduate Fellow)

